

TECHNICAL MANUAL

**OPERATION AND MAINTENANCE INSTRUCTIONS
WITH ILLUSTRATED PARTS BREAKDOWN
(ORGANIZATIONAL/INTERMEDIATE)**

**ANTENNA COUPLER,
CU-2310/URC, P/N 10094-0000**

HARRIS CORPORATION, RF COMMUNICATIONS GROUP
FO4606-82-D0079

BASIC AND ALL CHANGES HAVE BEEN
MERGED TO MAKE THIS A COMPLETE
PUBLICATION.

THIS PUBLICATION SUPERSEDES T.O. 31R2-2URC-111S-2 DATED 25 OCTOBER 1991.

DISTRIBUTION STATEMENT B - Distribution authorized to U.S. Government agencies only, for administration or operational use, 10 April 1992. Other requests for this document shall be referred to Sacramento ALC/TILBE, McClellan AFB, CA 95652-5990.

HANDLING AND DESTRUCTION NOTICE - Handle in compliance with distribution statement and destroy by any method that will prevent disclosure of the contents or reconstruction of the document.

PUBLISHED UNDER AUTHORITY OF THE SECRETARY OF THE AIR FORCE

**23 JULY 1985
CHANGE 4 - 20 MAY 1992**

LIST OF EFFECTIVE PAGES

NOTE: The portion of the text affected by the changes is indicated by a vertical line in the outer margins of the page. Changes to illustrations are indicated by miniature pointing hands. Changes to wiring diagrams are indicated by shaded areas.

Dates of issue for original and changed pages are:

Original.....0.....23 Jul 85
 Change.....1.....25 Nov 88
 Change.....2..... 1 Mar 90
 Change.....3.....26 Mar 91
 Change.....4.....20 May 92

Total number of pages in this publication is 90 consisting of the following:

Page No.	Change *No.	Page No.	Change *No.	Page No.	Change *No.
Title	4	FP-6 Blank	0		
A	4	FP-7	0		
i - xi	0	FP-8 Blank	0		
1-0 - 1-10	0	FP-9	0		
2-1 - 2-6	0	FP-10 Blank	0		
2-6A Added	2				
2-6B Blank Added ...	2				
2-7	2				
2-8	0				
2-9	2				
2-10 - 2-12	0				
2-13	2				
2-14	0				
3-1	3				
3-2	0				
4-1 - 4-2	0				
5-1 - 5-11	0				
5-12 Blank	0				
6-1 - 6-4	0				
6-5 - 6-6	3				
6-7	0				
6-8 - 6-9	4				
6-10 - 6-12	0				
6-13	4				
6-14	0				
7-1 - 7-3	0				
7-4 - 7-5	3				
7-6 - 7-7	0				
7-8 Blank	0				
8-1	0				
8-2 Blank	0				
FP-1	0				
FP-2 Blank	0				
FP-3	0				
FP-4 Blank	0				
FP-5	0				

*Zero in this column indicates an original page

SAFETY SUMMARY

The following are general safety precautions that are not related to any specific procedures and therefore do not appear elsewhere in this publication. These are recommended precautions that personnel must understand and apply during many phases of operation and maintenance.

KEEP AWAY FROM LIVE CIRCUITS

Operating personnel must at all times observe all safety regulations. Do not replace components with the power supply turned on. Under certain conditions, dangerous potentials may exist when the power control is in the off position, due to charges retained by capacitors. To avoid casualties, always remove power and discharge circuits to ground before touching any circuit components. Remove watches and rings before performing any maintenance procedures.

DO NOT SERVICE OR ADJUST ALONE

Under no circumstances should any person reach into or enter the enclosure for the purpose of servicing or adjusting the equipment except in the presence of someone who is capable of rendering aid.

RESUSCITATION

Personnel working with or near high voltages should be familiar with modern methods of resuscitation. Cardiopulmonary resuscitation procedures are outlined in T.O. 31-1-141-1, and annual refresher

training requirements are outlined in AFOSH STD 127-50.

The following warnings appear in the text in this volume, and are repeated here for emphasis.

WARNING

Improper grounding of the 100/500 Watt Antenna Coupler equipment can cause HIGH VOLTAGE to be present on the equipment chassis. The equipment ground should be checked with VIBROGROUND and should be 10 ohms or less.

WARNING

Drilling operations create metal chips that may enter the eyes. Goggles are required.

HANDLING OF ELECTROSTATIC DISCHARGE SENSITIVE DEVICES (ESDS)

Electrostatic Discharge Sensitive Devices (ESDS) must be handled with certain precautions that must be followed to minimize the effect of static build-up. Consult T.O. 00-25-234, DOD Std-1686, and DOD HDBK 263. ESDS devices are identified in this technical order by the following symbol:



TABLE OF CONTENTS

Section/Para		Page
CHAPTER 1. GENERAL INFORMATION		
1-1.	General Description and Purpose.....	1-1
1-2.	Equipment Functional Description.....	1-1
1-3.	Mechanical Design.....	1-2
1-4.	Leading Particulars.....	1-2
1-5.	Capabilities and Limitations.....	1-2
1-6.	Equipment and Accessories Supplied.....	1-2
1-7.	Equipment Required But Not Supplied.....	1-2
1-8.	Special Tools and Test Equipment.....	1-2
1-9.	Related Publications.....	1-2
CHAPTER 2. INSTALLATION		
I	INSTALLATION LOGISTICS	
2-1.	Equipment Unpacking Procedure.....	2-1
2-2.	Preparation for Installation.....	2-1
2-3.	Site Considerations.....	2-1
II	INSTALLATION PROCEDURE	
2-4.	Installing the Equipment.....	2-7
2-5.	100/500 Watt Antenna Coupler Mounting Instructions.....	2-7
2-6.	Cabling Connections.....	2-7
2-7.	Whip/Long Wire Jumper Selection.....	2-7
2-8.	Checking the Installation.....	2-8
CHAPTER 3. PREPARATION FOR USE AND RESHIPMENT		
I	PREPARATION FOR USE	
3-1.	Initial Control Settings.....	3-1
3-2.	Initial Power Application.....	3-1
3-3.	Step-By-Step Sequence for Initial Power Application.....	3-1
3-4.	Initial Checkout.....	3-1
3-5.	Step-By-Step Sequence for Checkout.....	3-1
II	PREPARATION FOR RESHIPMENT	
3-6.	Preparation for Reshipment.....	3-2
3-7.	Step-By-Step Disassembly Procedure.....	3-2
3-8.	Step-By-Step Packing and Crating Procedure.....	3-2
CHAPTER 4. OPERATION		
I	CONTROLS AND INDICATORS	
4-1.	Introduction.....	4-1
4-2.	Indications of Normal Operation.....	4-1
ii		

TABLE OF CONTENTS (Continued)

II	OPERATING INSTRUCTIONS		
	4-3. Introduction.....		4-2
CHAPTER 5. THEORY OF OPERATION			
I	GENERAL INFORMATION		
	5-1. Introduction.....		5-1
	5-2. Functional Operation and Signal Flow of RF Circuits.....		5-1
	5-3. Functional Operation of A1 Logic PWB Assembly Circuits.....		5-2
	5-4. Functional Operation and Signal Flow of Lower Shelf Assembly A2 Cicrcuits.....		5-2
II	100/500 WATT ANTENNA COUPLER CIRCUIT THEORY		
	5-5. Discriminator Circuits.....		5-3
	5-6. Reflected Power Detector.....		5-3
	5-7. Forward Power Detector.....		5-3
	5-8. RF On Threshold Detector.....		5-3
	5-9. 2:1 VSWR Threshold Detector.....		5-3
	5-10. 1.2:1 VSWR Threshold Detector.....		5-4
	5-11. Phase Error Detector.....		5-4
	5-12. Load Error Detector.....		5-4
	5-13. Control Logic.....		5-4
	5-14. Tuning Sequence Control.....		5-4
	5-15. Tune 1/Tune 2 Elements.....		5-5
	5-16. Bypass Relay Control.....		5-5
	5-17. Homing Circuit.....		5-6
	5-18. Tune Power Request.....		5-6
	5-19. RF Present Flip-Flop.....		5-7
	5-20. Long Wire Adapter Relay Control.....		5-8
	5-21. Servo Disable.....		5-8
	5-22. Key Disable Circuits.....		5-8
	5-23. Fault Flip-Flop.....		5-9
	5-24. Fan Control and Thermal Faults.....		5-9
	5-25. Servo System.....		5-9
	5-26. Power Supplies.....		5-10
CHAPTER 6. MAINTENANCE			
I	INTRODUCTION		
	6-1. Chapter Organization.....		6-1
	6-2. On-Equipment Maintenance Philosophy.....		6-1
	6-3. BIT (Built-In Test).....		6-1
II	PERFORMANCE TESTING AND TROUBLE ANALYSIS USING BIT		
	6-4. LED Indicators.....		6-2
	6-5. Troubleshooting with BIT.....		6-2

TABLE OF CONTENTS (Continued)

III	REMOVAL/REPLACEMENT PROCEDURES	
	6-6. Logic PWB Assembly.....	6-5
	6-7. Lower Shelf Assembly.....	6-5
IV	PERIODIC MAINTENANCE PROCEDURES	
	6-8. Periodic Maintenance Actions.....	6-6
V	ALIGNMENT PROCEDURES	
	6-9. Introduction.....	6-7
	6-10. Alignment Procedures.....	6-7

CHAPTER 7. ILLUSTRATED PARTS BREAKDOWN

I	INTRODUCTION	
	7-1. Purpose.....	7-1
	7-2. Scope.....	7-1
	7-3. Chapter Organization.....	7-1
	7-4. Source, Maintenance and Recoverability (SMR) Codes.....	7-1
	7-5. Federal Supply Codes for Manufacturers (FSCM).....	7-1
II	MAINTENANCE PARTS LIST	
	ILLUSTRATED PARTS BREAKDOWN	

CHAPTER 8. FOLDOUT DRAWINGS

I	LIST OF 100/500 WATT ANTENNA COUPLER FOLDOUT DRAWINGS	
	FO-1. Family Tree 100/500 Watt Coupler.....	FP-1
	FO-2. 100/500W Coupler Functional Block Diagram.....	FP-3
	FO-3. Components Location Diagram.....	FP-5
	FO-4. Antenna Coupler Interconnection Diagram.....	FP-7

LIST OF ILLUSTRATIONS

Figure		Page
CHAPTER 1. GENERAL INFORMATION		
1-1	Antenna Coupler CU-2310/URC	1-0
1-2	Simplified Functional Diagram	1-3
1-3	Identification of Subassemblies	1-4
CHAPTER 2. INSTALLATION		
2-1	Unpacking the Equipment	2-3
2-2	Basic 100/500 Watt Antenna Coupler Configurations	2-4
2-3	Typical 100/500 Watt Antenna Coupler Installation For Whip Antennas	2-5
2-4	Typical 100/500 Watt Antenna Coupler Installation For Long-Wire Antennas	2-6
2-5	100/500 Watt Antenna Coupler Dimensions	2-10
2-6	RF Input/Output Cable W1, Fabrication Detail	2-11
2-7	Dc Power and Control Cable W2, Fabrication Detail	2-12
2-8	Dc Power and Control Cable W2, Fabrication Detail	2-13
2-9	Safety Precautions for Fabrication of Cables	2-14
CHAPTER 6. MAINTENANCE		
6-1	100/500 Watt Antenna Coupler	6-8
6-2	Logic PWB Assy Component Layout	6-9
6-3	Capacitor C31	6-11
6-4	Variable Coil Roller Alignment	6-12
6-5	Ball Gap Assembly Adjustment	6-14
CHAPTER 7. ILLUSTRATED PARTS BREAKDOWN		
7-1	100/500 Watt Antenna Coupler, CU-2310/URC	7-4
7-2	Ancillary Kit for 100/500 Watt Antenna Coupler	7-6
CHAPTER 8. FOLDOUT DRAWINGS		
FO-1	Family Tree 100/500 Watt Coupler.....	FP-1
FO-2	100/500W Coupler Functional Block Diagram.....	FP-3
FO-3	Components Location Diagram.....	FP-5
FO-4	Antenna Coupler Interconnction Diagram.....	FP-7

LIST OF TABLES

Table		Page
CHAPTER 1. GENERAL INFORMATION		
1-1	Leading Particulars	1-5
1-2	Capabilities and Limitations	1-6
1-3	Equipment and Accessories Supplied	1-7
1-4	Equipment Required But Not Supplied	1-8
1-5	Optional Equipment	1-9
1-6	Related Publications	1-10
CHAPTER 2. INSTALLATION		
2-1	Interconnection Cabling Information	2-9
CHAPTER 6. MAINTENANCE		
6-1	Logic PWB Assembly LEDS and Their Functions	6-2
6-2	100/500 Watt Antenna Coupler Troubleshooting Chart	6-3
6-3	Test Equipment	6-7

GLOSSARY

A	Ampere(s)
A/D	Analog-to-Digital (Converter)
AFSK	Audio frequency shift keying; a baseband modulation scheme in which two audio frequencies are used to represent binary coded data; the frequency is shifted to one frequency to represent a 1 (mark) and to the other to represent a 0 (space).
AGC	Automatic gain control
ALE	Address latch enable
AM	Amplitude modulation; a modulation scheme in which the carrier is made to vary in amplitude in accordance with the modulating signal.
AME	Amplitude modulation equivalent
ANTIVOX	Prevents false VOX operation; see VOX
BFO	Beat Frequency Oscillator, used in SSB detection circuits
BIT	Built-in Test
BIU	Bus interface unit
BW	Bandwidth
CPU	Central processing unit
CREV	Converter reverse
CW	Continuous wave; a wave that does not vary in amplitude or frequency and is turned on and off to carry intelligence, e.g., Morse Code
D/A	Digital-to-Analog (Converter)
dB	Decibel(s)
dBm	Decibel(s) relative to one milliwatt
EMI	Electromagnetic interference
EPROM	Erasable programmable read-only memory
EU	Execution unit
HF	High frequency; a radio frequency band extending from about 3 MHz to 30 MHz; in this manual, HF includes 1.6 to 30 MHz.
HV	High voltage
IF	Intermediate frequency
IM	Intermodulation (distortion)
I/O	Input/Output
KREV	Keyer reverse
LCD	Liquid crystal display
LED	Light emitting diode
LPA	Linear power amplifier
LSB	Lower sideband; a modulation scheme in which the intelligence is carried on the first sideband below the carrier frequency; see SSB
MIC	Microphone
mA	Milliampere(s)
mV	Millivolt(s)
NBSV	Narrow band secure voice
PEP	Peak envelope power
PPC	Peak power control
PWB	Printed wiring board
RAM	Random access memory
rms	Root mean square
RTC	Real time clock
RX	Receive

GLOSSARY (Continued)

S TONE	Sidetone
SSB	Single sideband; a modulation scheme in which the intelligence is carried by one of the carrier sidebands, the other side band and the carrier center frequency being suppressed
TGC	Transmitter gain control
TX	Transmit
uA	Microampere(s)
uP	Microprocessor
USB	Upper sideband; a modulation scheme in which the intelligence is carried on the first sideband above the carrier frequency; see SSB
uV	Microvolt(s)
Vac	Volts, alternating current
VCO	Voltage controlled oscillator
Vdc	Volts, direct current
VOX	Voice operated transmission
VSWR	Voltage standing wave ratio; the ratio of the maximum to the minimum voltage of a standing wave on a radio frequency transmission line
W	Watt(s)

INTRODUCTION

The purpose of this on-equipment level manual is to provide all information necessary for the installation, operation and on-equipment maintenance of Coupler, Antenna, CU-2310/URC, manufactured by the RF Communications Group of Harris Corporation, Rochester, New York. The manual is divided into eight chapters. The contents of each chapter are briefly described in the following paragraphs.

Chapter 1 provides a general description and a list of capabilities and limitations of Coupler, Antenna CU-2310/URC. A list of companion equipment references are included along with the components that form the CU-2310/URC.

Chapter 2 provides the information necessary for planning and carrying out the installation of the Coupler, Antenna CU-2310/URC. A dimensional outline drawing is provided to show dimensions and other information required for proper installation.

Chapter 3 provides instructions for preparing the Coupler, Antenna, CU-2310/URC for use, including the initial application of power and checkout. Instructions for repacking the equipment for reshipment are also included in Chapter 3.

Chapter 4 provides complete operating instructions for the Coupler, Antenna, CU-2310/URC in all modes and contains a list of operating controls and indicators.

Chapter 5 provides a complete theory of operation for the Coupler, Antenna CU-2310/URC. An overall theory and detailed theory of individual functional circuits are provided.

Chapter 6 describes the on-equipment location maintenance procedures. On-equipment location maintenance is based on the use of built-in test (BIT) features of the equipment to isolate problems to the replaceable subassembly or printed wiring board (PWB) level. Depot maintenance is supplied in a separate publication, T.O. 31R2-2URC-113. The Depot Manual is based on performance testing and trouble analysis of the subassembly or PWB to locate and replace faulty parts at the lowest replaceable unit level (LRU).

Chapter 7 contains the Illustrated Parts Breakdown (IPB) information at the on-equipment level. This includes assemblies and parts that may be replaced at the on-equipment location.

Chapter 8 contains all fold-out (FO) drawings. A cross reference list is provided as well as the individual drawings referenced throughout chapters 1 to 7. The diagrams are numbered FO-1, FO-2, etc. They are printed on sheets with page-size blank aprons to permit viewing the diagram with the rest of the book closed or opened to another page.

APPLICABLE SPECIFICATIONS

The following specifications, standards, and publications were used in the preparation of this manual.

SPECIFICATION	NAME
MIL-M-38798B, para. 3.4	Combined Operation and Maintenance Instructions Manual (Equipment).
MIL-M-38807, Amend. 4	Preparation of Illustrated Parts Breakdown.
MIL-M-38790 and MIL-M-38784A	General Requirements for Preparation of Technical Manuals.

APPLICABLE STANDARDS

STANDARD	NAME
MIL-STD-12	Abbreviations for use on Drawings and in Technical Type Publications.
MIL-STD-15-1A	Graphic Symbols for Electrical Components.
MIL-STD-17-1	Mechanical Symbols.
MIL-STD-806	Graphic Symbols for Logic Diagrams.

APPLICABLE PUBLICATIONS

PUBLICATION	NAME
DOD 5200.20	Distribution Statements on Technical Documents.
USAS Y14.15-1966	Electrical and Electronic Diagrams.
USAS Y32.16-1968	Electrical and Electronic Reference Designations.
T.O. 31-1-141 (Series)	Technical Manual-Basic Electronic Technology and Testing Practices.

APPLICABLE STANDARDS

STANDARD	NAME
MIL-STD-12	Abbreviations for use on Drawings and in Technical Type Publications.
MIL-STD-15-1A	Graphic Symbols for Electrical Components.
MIL-STD-17-1	Mechanical Symbols.
MIL-STD-806	Graphic Symbols for Logic Diagrams.

APPLICABLE PUBLICATIONS

PUBLICATION	NAME
DOD 5200.20	Distribution Statements on Technical Documents.
USAS Y14.15-1966	Electrical and Electronic Diagrams.
USAS Y32.16-1968	Electrical and Electronic Reference Designations.
T.O. 31-1-141 (Series)	Technical Manual-Basic Electronic Technology and Testing Practices.

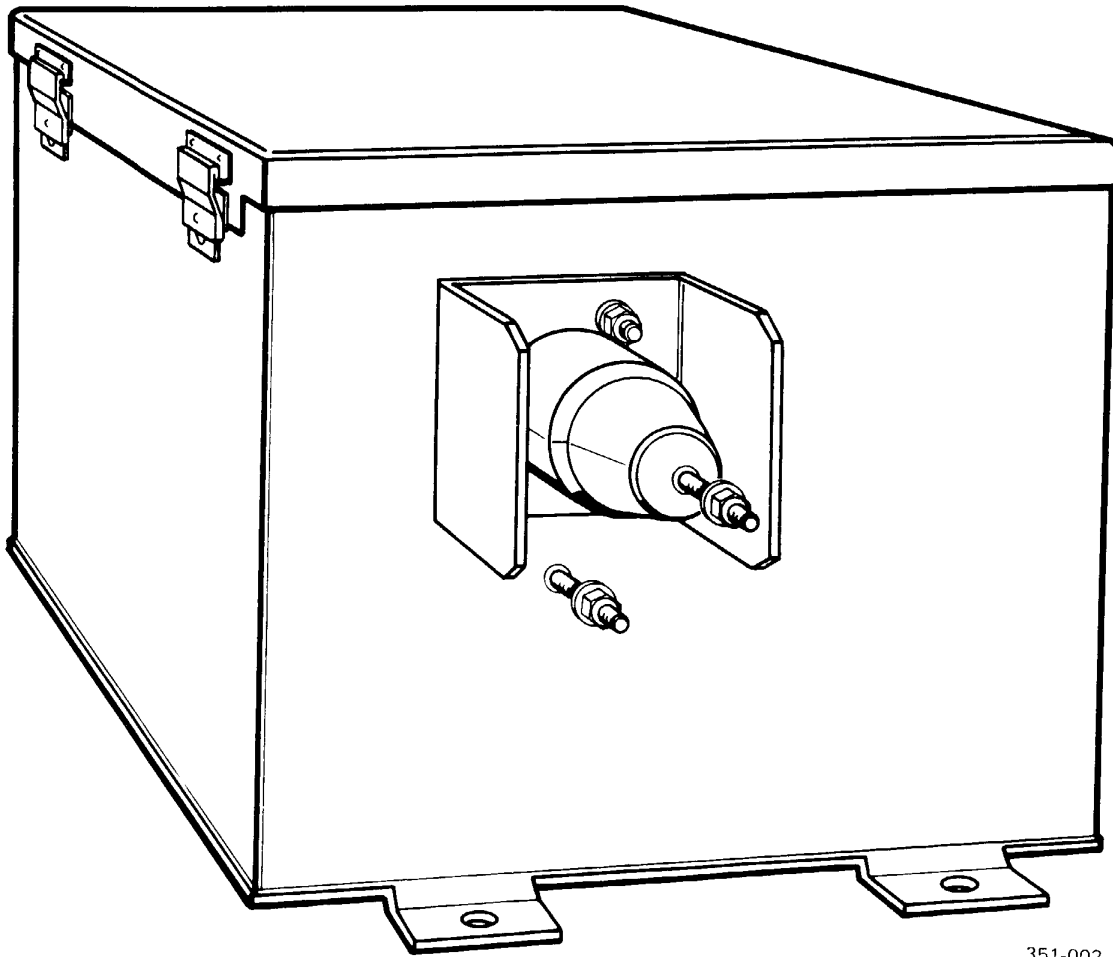

Figure 1-1. Antenna Coupler CU-2310 URC

CHAPTER 1

GENERAL INFORMATION

1-1. GENERAL DESCRIPTION AND PURPOSE. Antenna Coupler CU-2310/URC, shown in figure 1-1, and hereafter known as the 100/500 Watt Antenna Coupler, automatically matches the output impedance of the Transmitter-Receiver RT-1446/URC, (hereafter known as 100 Watt Transceiver) or Radio Frequency Amplifier AM-7223/URC, (hereafter known as 500 Watt LPA) to a whip or longwire antenna over the frequency range of 1.6 to 30 MHz. Operation, including network tuning and monitoring, is fully automatic. Tuning time is typically five to eight seconds.

a. **Applications.** The 100/500 Watt Antenna Coupler is used in applications where the required characteristic load impedance is other than 50 ohms. Typically, antennas do not exhibit a constant 50 ohm impedance over the 1.6 MHz to 30 MHz range. The 100/500 Watt Antenna Coupler matches the antenna to the 100 Watt Transceiver or 500 Watt LPA so that at the operating frequency a 50 ohm load is presented to the transmitter.

b. **Reliability.** The 100/500 Watt Antenna Coupler is designed for continuous operation under the most severe environmental conditions. Automatic sensing circuitry protects the 100/500 Watt Antenna Coupler from defective antennas or internal malfunctions.

c. **Remote Operation.** The 100/500 Watt Antenna Coupler permits remote location of the antenna up to 150 feet from the 100 Watt Transceiver or 250 feet from the 500 Watt LPA.

d. **Test Features.** The 100/500 Watt Antenna Coupler contains built-in-test (BIT) features that are used to locate malfunctions to areas of possible problems.

e. **Power Requirements.** Primary power at +13.6 Vdc is supplied to the 100/500 Watt Antenna Coupler from the 100 Watt Transceiver.

1-2. EQUIPMENT FUNCTIONAL DESCRIPTION.

a. **Tuning.** Figure 1-2 is a simplified block diagram of the 100/500 Watt Antenna Coupler. The rf signal path is shown by a heavy line. In the rf signal path are: a Discriminator Sampling Circuit, which samples voltages and current on the rf line; an Impedance Matching Transformer A1T2, which matches the coupler operating impedance of 12.5 ohms to the standard 50 ohm transmission line; Main Tuning Capacitor A2C1; Main Tuning Inductor A2L1; and Long Wire Antenna Adapter Capacitors A2A3C1, A2A3C2 and A2A3C3, which are placed in the circuit when needed to tune a long wire antenna. Relay A2K1 inserts or removes these capacitors. Relays A1A1K1 and A2K2 provide the means for bypassing the tuning elements in the rf path to provide an rf path through the 100/500 Watt Antenna Coupler when it is not tuned to a specific transmitting frequency. This allows reception to take place when the 100/500 Watt Antenna Coupler is untuned. Automatic tuning is initiated when the 100/500 Watt Antenna Coupler receives a TUNE PULSE from the 100 Watt Transceiver. The control logic circuits initiate a sequence of control signals that cause the servo system to first drive the tuning elements, A2C1 and A2L1, to their home positions without rf power applied from the 100 Watt Transceiver. Then a TUNE POWER request is sent to the 100 Watt Transceiver and A2C1 and A2L1 are tuned using a low power rf tuning signal supplied by the 100 Watt Transceiver. During tuning, the LOAD ERROR and PHASE ERROR are reduced until the voltage standing wave ratio (VSWR) on the rf line is less than 1.2:1. If this is not achieved on the first attempt, relay A2K1 energizes or deenergizes (depending on the position of the jumper on the Logic Control Board), placing the Long Wire Adapter Capacitors in the rf path or removing them, and the tuning cycle is repeated. When the VSWR is reduced below 1.2:1, the servo system is disabled and the keying circuit of the 100 Watt Transceiver is enabled so that full power transmitting can take place.

b. **Monitoring.** After tuning is accomplished, the discriminator continues to monitor the VSWR. If the VSWR exceeds 2:1, the logic circuits react by disabling the keying circuit, after which the tuning

T.O. 31R2-2URC-111

cycle must be repeated. If tuning is not accomplished (VSWR < 1.2:1) within 20 seconds after the initiation of a tuning cycle, the control logic sends a TUNE TIME FAULT signal to the 100 Watt Transceiver for display. If the internal temperature of the 100/500 Watt Antenna Coupler exceeds 95°C, a THERMAL FAULT signal is sent to the 100 Watt Transceiver. Both fault signals are displayed on the 100 Watt Transceiver front panel.

1-3. MECHANICAL DESIGN. The mechanical construction of the 100/500 Watt Antenna Coupler is shown in figure 1-3. It consists of two major assemblies: Logic PWB Assembly A1 and Lower Shelf Assembly A2. Logic PWB Assembly A1, which is located in the upper portion of the Chassis Assembly, contains RF PWB Assembly A1A1. Lower Shelf Assembly A2 consists of Servo Drive Assembly A2A1, and Capacitor Assembly A2A3. The tunable components of the 100/500 Watt Antenna Coupler are located on the Lower Shelf Assembly A2 while the antenna tuning control components are located on the Logic PWB Assembly A1. An internal cooling fan operates during transmission when the 100/500 Watt Antenna Coupler is operated with a 500 Watt LPA. The top cover of the Chassis Assembly is removable so that all other assemblies are accessible for removal or maintenance. When the top cover is removed, Logic PWB Assembly A1 can be removed by unplugging four connectors. With the A1 assembly removed the Lower Shelf Assembly A2 components and subassemblies are accessible for maintenance.

1-4. LEADING PARTICULARS. The

characteristics of the 100/500 Watt Antenna Coupler are summarized in table 1-1. This table includes physical data and operating/storage environment data.

1-5. CAPABILITIES AND LIMITATIONS. The capabilities and limitations of the 100/500 Watt Antenna Coupler are described in table 1-2.

1-6. EQUIPMENT AND ACCESSORIES SUPPLIED. Table 1-3 lists the supplied assemblies, components, units, cables, and accessory kits that pertain to the 100/500 Watt Antenna Coupler.

1-7. EQUIPMENT REQUIRED BUT NOT SUPPLIED. Table 1-4 lists equipment required, but not supplied, for the installation and operation of the 100/500 Watt Antenna Coupler. The 100/500 Watt Antenna Coupler is always used with an HF transmitter and/or receiver and with one of several antenna types. It requires an RF input in the HF band not exceeding 500 watts PEP and a unique set of logic control signals for its operation. It is specifically designed to interface with the equipment listed in table 1-5.

1-8. SPECIAL TOOLS AND TEST EQUIPMENT. The servicing and maintenance of the 100/500 Watt Antenna Coupler does not require any special tools, test jigs, or fixtures at the on-equipment level.

1-9. RELATED PUBLICATIONS. Table 1-6 lists the Technical Order publications related to use of the 100/500 Watt Antenna Coupler.

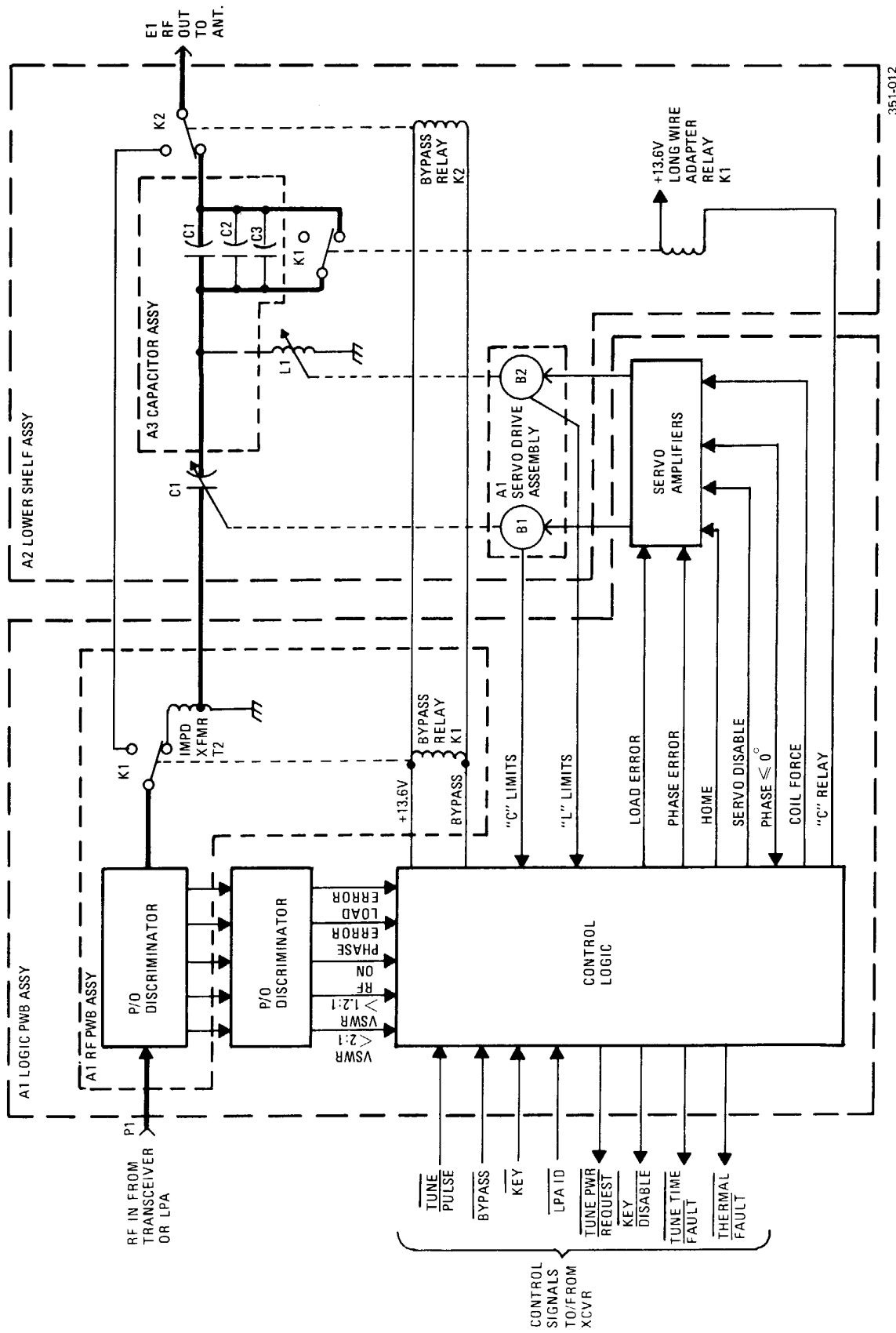

351-012

Figure 1-2. Simplified Functional Diagram

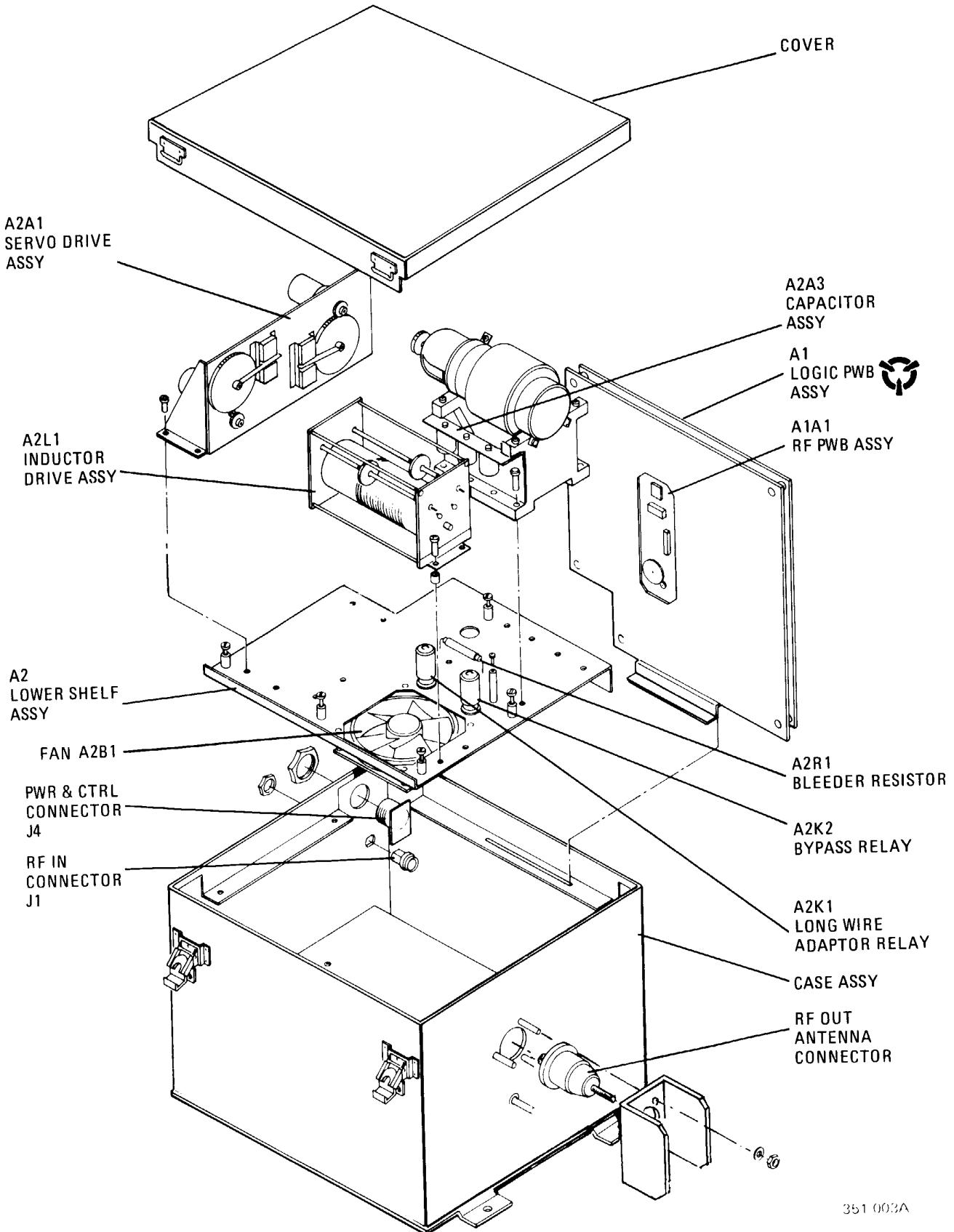

351 003A

Figure 1-3. Identification of Subassemblies

Table 1-1. Leading Particulars

Item	Characteristic or Value:
Dimensions: Height: Width: Depth:	11.0 inches (27.9 cm) 16.0 inches (40.6 cm) 18.0 inches (45.7 cm)
Weight:	25 pounds (11.3 kg)
Power Requirements:	DC power +13.6 Vdc, 5 Amps(maximum)
Operating Environment:	-30 to +65 degrees C, 95% Humidity Waterproof (sealed); designed for exposed installations
Storage Environment:	-35 to +70 degrees C, 95% Humidity
Operating Altitude:	10,000 feet
Transport Altitude:	40,000 feet
Shock/Vibration:	MIL-STD-810C
Cooling:	Convection and forced air (built-in fan)
Cabling Requirements:	Front/Rear Panel Connections W1P1 - RF Input/Output E1 - Antenna Output/Input A3P1 - Control and Power Input
Transportability:	Manual Methods Apply
Set-up Time:	Less than 1 hour

Table 1-2. Capabilities and Limitations

Description of Characteristic	
Use:	Impedance matching between an antenna and a 100 to 500 watt transmitter or a 500 watt power amplifier (e.g. Receiver-Transmitter, Radio, RT-1446/URC and Amplifier, Radio Frequency, AM-7223/URC).
Frequency Range and Tuning Capability:	1.6 to 30 MHz: Tunes to 15 to 35 ft.(4.52 to 10.67m) whip antennas. Tunes to 75 to 150 ft. (22.86 to 45.72m) long wire antennas.
Maximum Rated RF Input Power:	250 watts average, 500 watts PEP
Tuning Mode:	Fully automatic
Tuning Accuracy:	1.2:1 VSWR or less, referenced to 50 ohms
Features:	Automatic re-tune if high VSWR; automatic receive capability in untuned state; BIT (Built-in Test)
Primary Power:	13.6 Vdc ±10%
Remote Capability:	Up to 150 ft. (45.7m) separation between 100 Watt Transceiver and the 100/500 Watt Antenna Coupler; up to 250 ft. (76.2m) separation between the 500 Watt LPA and the 100/500 Watt Antenna Coupler
Control Lines: NOTE: An overlined signal name indicates that the signal is active when the logic level is zero (ground)	<p><u>TUNE PULSE</u>: Ground when 100 Watt Transceiver requests tuning</p> <p><u>FAULT</u>: Ground when reporting TUNE TIME faults</p> <p><u>KEY</u>: Ground when transmitter is keyed</p> <p><u>LPA ID</u>: Ground when 100/500 Watt Antenna Coupler is connected to 500W LPA</p> <p><u>KEY DISABLE</u>: Ground sent to 100 Watt Transceiver to disable the KEY signal</p>

Table 1-2. Capabilities and Limitations (Continued)

Description of Characteristic	
	<p><u>THERMAL FAULT:</u> Ground when reporting a coupler over temperature</p> <p><u>BYPASS:</u> Ground when 100 Watt Transceiver requests bypass of 100/500 Antenna Coupler</p> <p><u>TUNE PWR REQ:</u> Ground when 100/500 Watt Antenna Coupler requests tuning power from the 100 Watt Transceiver</p>
100 Watt Transceiver Interfaces:	RF coaxial line and a twelve wire power and control cable
Tune Power Requirements:	25 watts carrier

Table 1-3. Equipment and Accessories Supplied

Qty	Item	Use
1	100/500 Watt Antenna Coupler CU-2310/URC, 10094-0100	
1	Ancillary Kit, 10094-0060, consisting of the items listed below	Provides mounting hardware and interace connectors
1	Connector, 14 Pin MS3106R20-27S	Mates with A3P1 on Rear Panel of Antenna Coupler
2	Cable Clamp MS3057-12B	Clamps Connectors at each End of Control Cable
2	Cable Clamp 10-36233-243	Clamps Connectors at each End of Control Cable

Table 1-3. Equipment and Accessories Supplied (Continued)

Qty	Item	Use
2	Bushing MS3420-12B	Used with above listed Clamps
1	Connector MS3106A20-27P	Mates with J5 on 100 Watt Transceiver

Table 1-4. Equipment Required But Not Supplied*

Qty	Item	Description
1	Antenna (See table 1-2.)	Required for reception and transmis- sion of radio signals.
1	Receiver-Transmitter, Radio RT-1446/URC NSN-5820-01-162-3402	Companion equipment used for reception and transmission of RF signals.
As required	Silicone Compound, Dow Corning No. DC-5 (FSCM: 71984)	Used to seal cork gasket and insulator assembly to antenna coupler case.
As required	Coaxial cable, RG-142 B/U	Used to fabricate RF cables W1 and W2.

*See table 6-3 for test equipment required.

Table 1-5. Optional Equipment

Qty	Item	Use
1	Remote Control Unit C-11329/URC	Companion equipment used where it is desired to operate the 100 Watt Transceiver from a remote location.
1	Amplifier, Radio Frequency AM-7223/URC	Companion equipment used for increased (500 W) RF power.
1	Transport Case CY-8361/URC, which includes the items listed below	Optional case for transporting the 100/500 Watt Antenna Coupler and connecting cables.
1	Control Cable (150 ft.) 10094-4150	Connects to 100 Watt Transceiver.
3	RF Cables (50 ft.) 10094-5050	Connects to 100 Watt Transceiver or 500 Watt LPA.
2	Adapter, Female M55339/07-00029	For connecting the RF cables.

Table 1-6. Related Publications

Title	Publication No.
100/500 Watt Antenna Coupler, CU-2310/URC On-Equipment Manual Depot Manual Work Cards	T.O. 31R2-2URC-111 T.O. 31R2-2URC-113 T.O. 31R2-2URC-116WC-1
Receiver-Transmitter, Radio, RT-1446/URC On-Equipment Manual Depot Manual Work Cards	T.O. 31R2-2URC-81 T.O. 31R2-2URC-83 T.O. 31R2-2URC-86WC-1
Amplifier, Radio Frequency, AM-7223/URC On-Equipment Manual Depot Manual Work Cards	T.O. 31R2-2URC-101 T.O. 31R2-2URC-103 T.O. 31R2-2URC-106WC-1
Power Supply, PP-7913/URC On-Equipment Manual Depot Manual Work Cards	T.O. 35C1-2-892-1 T.O. 35C1-2-892-3 T.O. 35C1-2-892-6WC-1
Amplifier, Radio Frequency, AM-7224/URC On-Equipment Manual Depot Manual Work Cards	T.O. 31R2-2URC-121 T.O. 31R2-2URC-123 T.O. 35C1-2-892-6WC-1
Remote Control Unit, C-11329/URC On-Equipment Manual Depot Manual Work Cards	T.O. 31R2-2URC-91 T.O. 31R2-2URC-93 T.O. 31R2-2URC-96WC-1
Overall System Work Cards	T.O. 31R2-2URC-126WC-1

CHAPTER 2

INSTALLATION

WARNING

Dangerous voltages exist in this radio equipment. Before removing any covers, disconnect the primary power and the RF source.

Section I. INSTALLATION LOGISTICS

2-1. EQUIPMENT UNPACKING PROCEDURE. The 100/500 Watt Antenna Coupler is packed in a corrugated cardboard box for shipment. A two-piece foam enclosure protects the equipment from rough handling.

- a. When the unit is received, carefully inspect the exterior of the box. Look for any damage, signs of rough handling or weather exposure (e.g., water damage) or signs that the box may have been tampered with. If any of these conditions are present, carefully note and report them to the proper authority (refer to T.O. 00-35D-54). An external sticker on the shipping box provides additional instructions concerning inspection of the package.
- b. Refer to figure 2-1 for instructions concerning unpacking the box. Since the box consists of double-walled cardboard with reinforced strapping tape, the tool required to open the box is a sharp knife. Use the knife carefully to avoid injury when opening the box. Keep the packing box in a secure place for possible future use.
- c. After removing the equipment from the box, use the packing list in the ancillary package to verify the presence of each item in the shipment. Any shortages of items should be reported to the proper authority (refer to T.O. 00-35D-54).
- d. The boxed equipment weighs a total of 35 pounds (15.8 Kg). Use normal care to move the boxed equipment into the general location where it is to be installed. Once unpacked, the 100/500 Watt Antenna Coupler weighs a total of 25 pounds and may be handled by one individual.

2-2. PREPARATION FOR INSTALLATION. Site selection is the most important consideration in preparing for installation of the equipment. Details for site selection will vary depending on the use of the 100/500 Watt Antenna Coupler.

2-3. SITE CONSIDERATIONS. A number of factors should be considered, from security to operational requirements, and it is the responsibility of the user to determine which has precedence. Each of the following items should be considered in site selection:

- a. Power Source. Power requirements are identified in table 1-1.
- b. Loading. Depending on the installation method, be sure the selected space has adequate strength to support the weight of the equipment.
- c. Accessibility. Consider the space needed for access to the equipment for servicing, operating, maintenance, etc.
- d. Antenna System. Location of the 100/500 Watt Antenna Coupler should take into account the antenna cable and, if used, antenna patch panel equipment. Avoid unnecessarily long antenna cable runs. Be sure the maximum length of the 100/500 Watt Antenna Coupler control cable does not exceed 150 ft. The 100/500 Watt Antenna Coupler should not be more than 150 ft. from the 100 Watt Transceiver or 250 ft. from the 500 Watt LPA.
- e. System Ground. Make sure the system is properly grounded, both for safety (e.g., lightning hazard) and for proper operation of the antenna system. Refer to T.O. 31-10-24. A good ground is 10 ohms or less.

f. Environment. The 100/500 Watt Antenna Coupler will operate normally over an ambient temperature range of -30 to + 65 degrees C.

g. Interaction. The possibility of interaction between the 100/500 Watt Antenna Coupler and other electronic equipment in the vicinity does exist. Avoid this possibility whenever possible by installing the 100/500 Watt Antenna Coupler in a location well away from other equipment. Avoid running the coupler control cable parallel to the antenna or the ground strap.

h. Heat Dissipation. Heat dissipation is not normally a problem with the 100/500 Watt Antenna Coupler.

i. Mounting. When the site has been selected, the method of mounting the equipment should be considered. Most installations of the equipment will result in one of the mounting techniques described in the following paragraphs.

j. Installation Configuration. As shown in figure 2-2, there are two basic equipment configurations for 100/500 Watt Antenna Coupler site installation: in one configuration, the 100/500 Watt Antenna Coupler is connected directly to the 100 Watt Transceiver. In the other configuration, the 100/500 Watt Antenna Coupler is connected to a 500 Watt Linear Power Amplifier and is controlled by the 100 Watt Transceiver. Either of the two equipment configurations may be used with a whip or a long-wire antenna, depending upon the particular application of the equipment.

k. Grounding. Proper grounding of the 100 Watt Antenna Coupler is necessary to prevent degraded operation of the system. Improper grounding can cause equipment malfunctions and possible serious personnel hazards. Refer to T.O. 31-10-24. A good ground is 10 ohms or less.

WARNING

Improper grounding of the 100/500 Watt Antenna Coupler equipment can cause HIGH VOLTAGE to be present on the equipment chassis. The equipment ground should be checked with VIBROGROUND and should be 10 ohms or less.

The ground straps should be constructed of wide copper material, and should be as short as possible. Ground straps should be clamped and bonded to at least two ground stakes or ground rods. The stakes, or rods, should be at least 6 to 8 feet (1.83 to 2.44 meters) long, and should be spaced more than one rod length apart and equally spaced about the 100/500 Watt Antenna Coupler ground terminal. Sufficient rods should be used to obtain a 10 ohms or less reading. If ground stakes or rods cannot be used (e.g., installation on a roof or inside a building), the ground connection should be made to a cold water pipe or other metal conductor that provides a good ground.

l. Typical 100/500 Watt Antenna Coupler Installation for Whip Antennas. If a whip antenna is used, connect the antenna insulator on the 100/500 Watt Antenna Coupler to the base of the whip with a heavy flexible insulated cable, such as the insulated inner conductor of a length of RG-8/U. This cable should be kept as short as possible; it should not exceed 2.5 feet (0.762m) in length. A typical fixed whip antenna installation is shown in figure 2-3.

m. Typical 100/500 Watt Antenna Coupler Installation For Long-Wire Antennas. When using 75 or 150 foot (22.86 or 45.72m) long-wire type antennas, it is advisable to mount the 100/500 Watt Antenna Coupler as close to the antenna base as possible. Cable type and installation precautions for this type of antenna installation are basically the same as for whip type antennas. A typical long-wire type antenna installation is shown in figure 2-4.

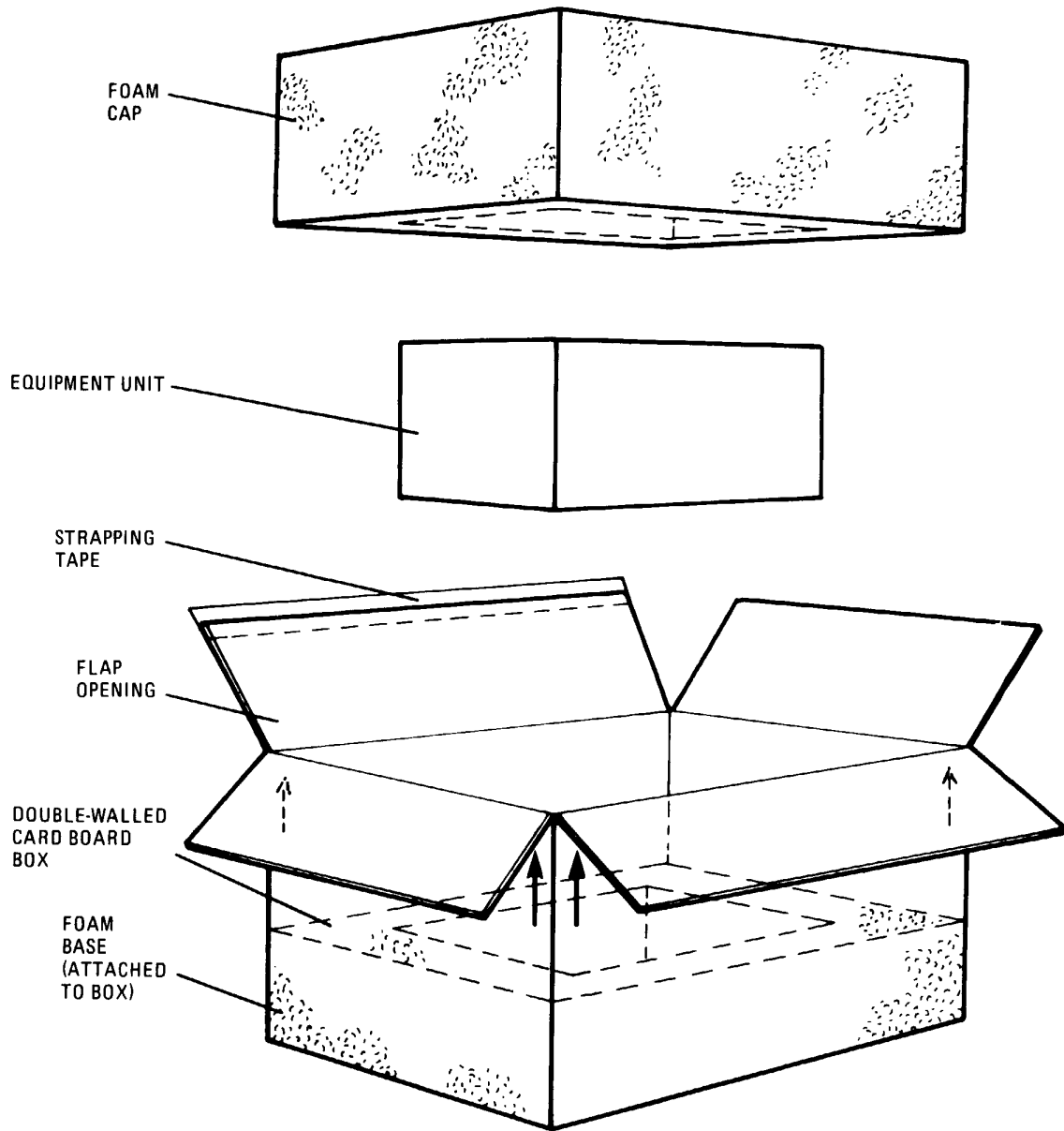

UNPACKING PROCEDURE

1. PLACE BOX ON FLOOR WITH ARROWS MARKED ON EACH SIDE POINTING UP.
2. CUT TAPE ON TOP OF BOX AND REMOVE FOAM CAP FROM BOX.
3. LIFT EQUIPMENT UNIT OUT OF BOX.
4. SAVE BOX AND FOAM CAP FOR RESHIPMENT.

350-003

Figure 2-1. Unpacking the Equipment

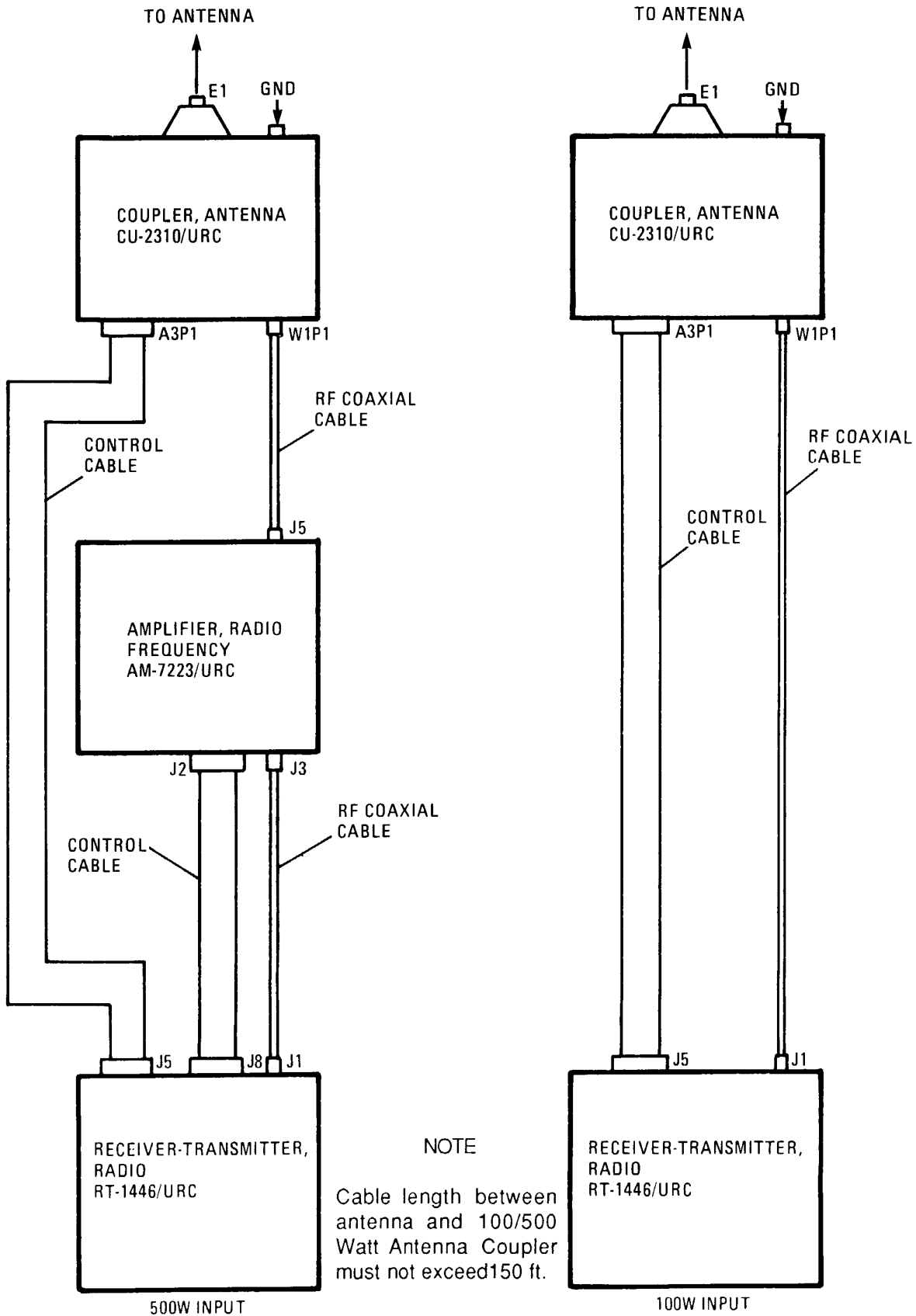

Figure 2-2. Basic 100/500 Watt Antenna Coupler Configurations

351-006

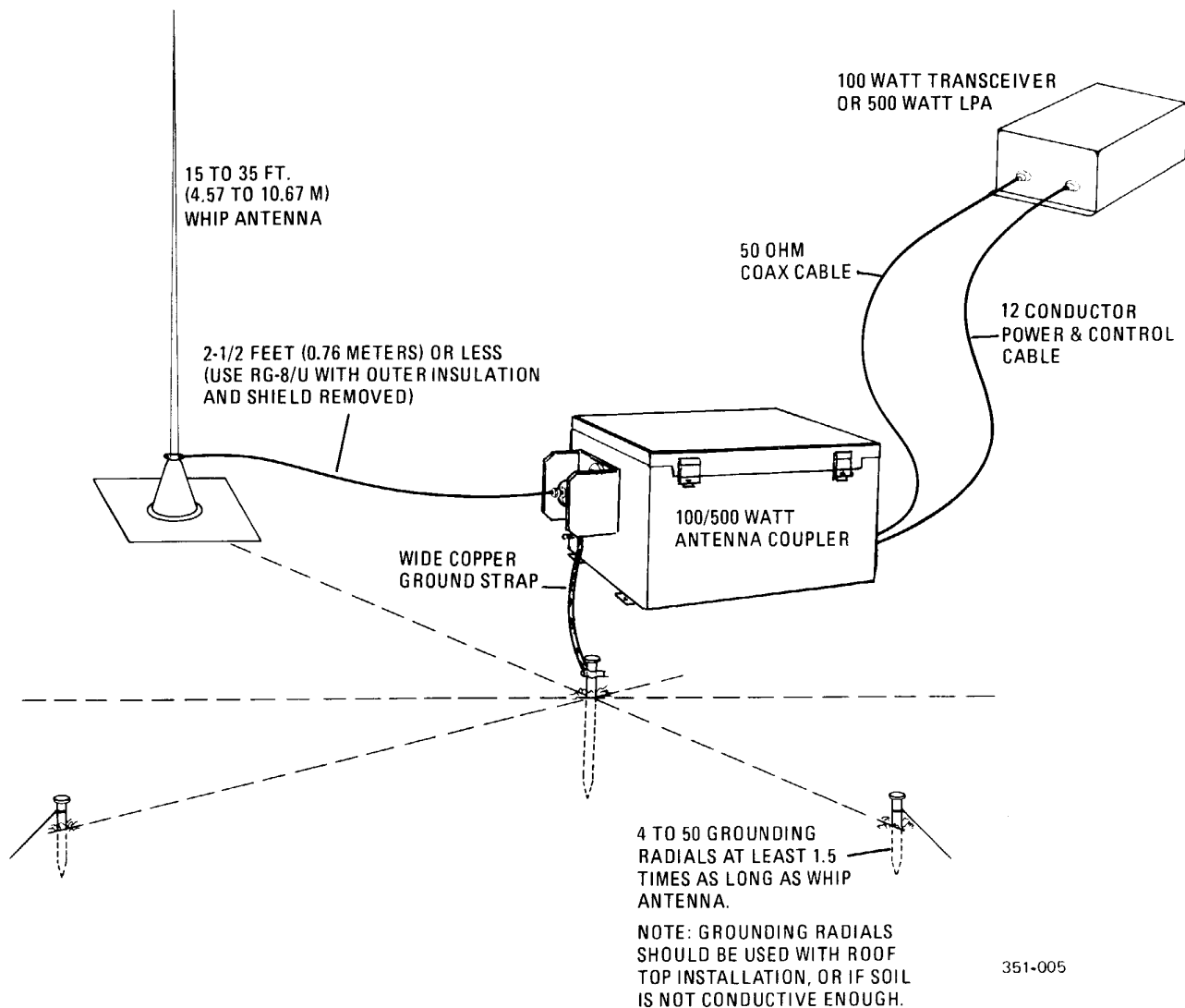

Figure 2-3. Typical 100/500 Watt Antenna Coupler Installation For Whip Antennas

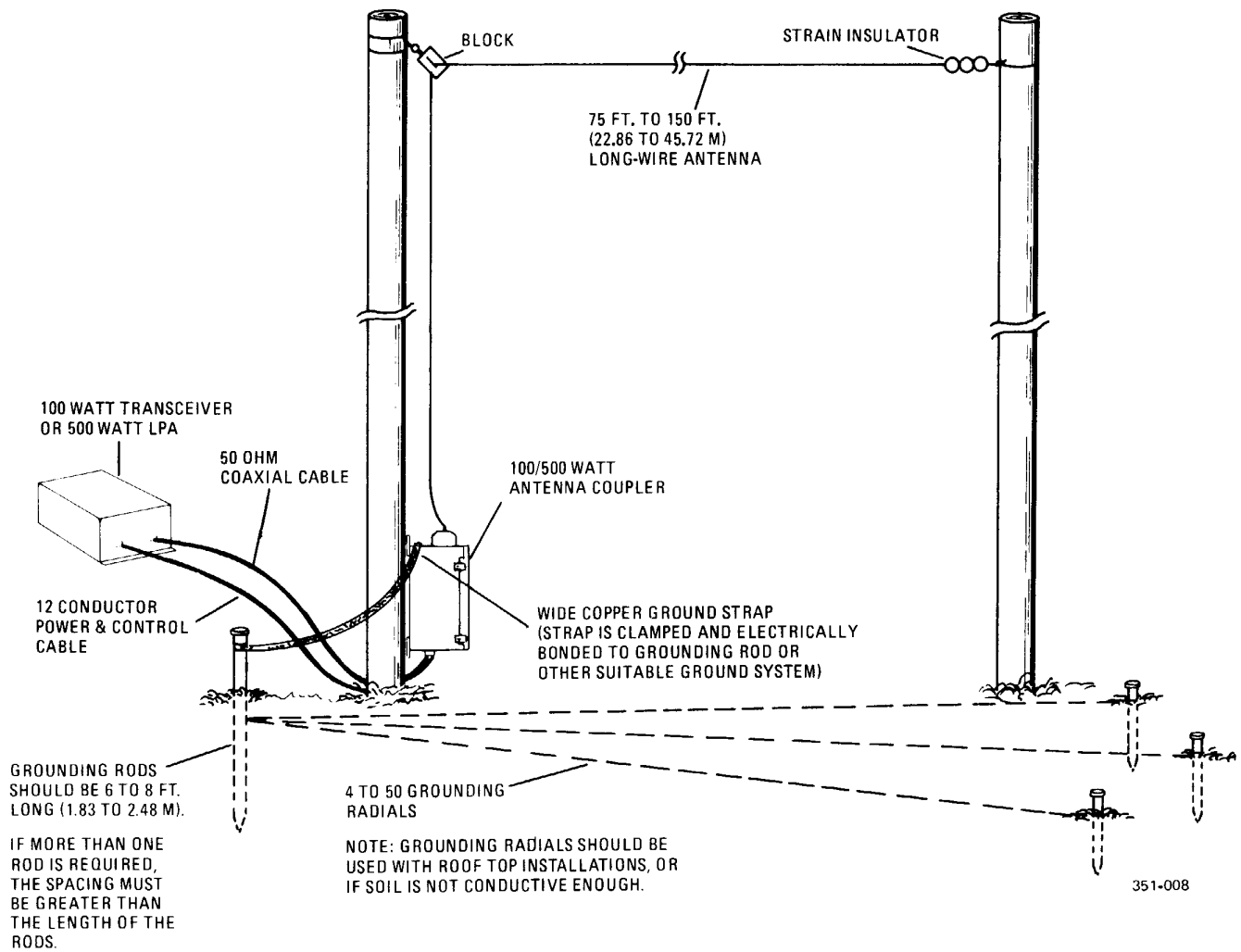

Figure 2-4. Typical 100/500 Watt Antenna Coupler Installation For Long-Wire Antennas

Section II. INSTALLATION PROCEDURE

2-4. **INSTALLING THE EQUIPMENT.** After unpacking the equipment and selecting the site, install the 100/500 Watt Antenna Coupler as described in the following paragraphs.

a. Time Requirement. Installation should not take more than one hour depending on the type of antenna used. This figure does not include the time necessary to install the antenna or any companion equipment, or to fabricate cables.

b. Tool Requirements. Installation is accomplished with common hand tools, e.g., socket wrenches, screwdrivers, pliers, etc.

c. Personnel Requirements. Equipment positioning requires one or two individuals to lift and place the unit in position. Once the equipment is positioned and secured, one person can complete the installation in approximately 30 minutes.

2-5. 100/500 WATT ANTENNA COUPLER MOUNTING INSTRUCTIONS.

- a. The exact method of mounting the 100/500 Watt Antenna Coupler depends upon the type of installation selected. Refer to figure 2-5 for 100/500 Watt Antenna Coupler dimensions. Make sure that the mounting surface allows adequate room for 100/500 Watt Antenna Coupler and has proper clearance for cable interconnection.

WARNING

Drilling operations create metal chips that may enter the eyes. Goggles are required.

- b. Refer to figures 2-3 and 2-4, depending upon the type of installation selected. Mark off the four mounting hole centers on the mounting surface. Drill four mounting holes using a standard 3/8 inch (3.375 inch or 0.95 cm) drill bit.
- c. Secure 100/500 Watt Antenna Coupler to mounting surface using appropriate hardware. Hardware selected should be of the appropriate type for the 0.375 inch mounting holes. Use 5/16-18 bolts, nuts, washers, and lockwashers to secure the 100/500 Watt Antenna Coupler to the mounting surface.

2-6. **CABLING CONNECTIONS.** After the equipment has been positioned and secured, fabricate and connect the 100/500 Watt Antenna Coupler cables as described in the following paragraphs. Avoid running cables parallel to the antenna or the ground strap.

- a. Interconnection and Interface. Variations among installations will determine the lengths of the cables connecting the 100/500 Watt Antenna

Coupler to the antenna and the 100 Watt Transceiver or the 500 Watt LPA. Connectors are supplied. The user is responsible for fabrication of the cables. Refer to figure 2-2 for the identification of cables required with a specific type of installation.

CAUTION

Care should be exercised when fabricating cables to insure proper wiring interconnection of cable connector pins. Miswiring can result in severe damage to equipment.

b. Cable Fabrication. Detailed information on cable fabrication is provided in table 2-1 and figures 2-6 and 2-7. Table 2-1 contains interconnection information. The fabrication of cable W1 is shown in figure 2-6. The fabrication of cable W2 is shown in figure 2-7. Equivalent wire gauge of 18 AWG is recommended for the power and ground conductors of W2.

2-7. WHIP/LONG WIRE JUMPER SELECTION. A jumper on the Logic Control PWB Assembly can be placed in one of two positions. This jumper selects whether the long wire adapter is inserted on the first tune sequence or on the second tune sequence.

a. If the antenna to be used is a whip or equivalent place the jumper in the WHIP (J9) position. This will cause the coupler to tune first without the long wire adapter in the circuit.

b. If the antenna to be used is a long wire or equivalent, place the jumper in the LONG WIRE (J10) position. This will cause the coupler to tune first with the long wire adapter in the circuit.

c. If there is any doubt as to where the jumper is to be placed, place the jumper in the WHIP (J9) position. In either case, the coupler will tune either type of antenna. The placement of the jumper will only reduce the coupler tune time and will not affect the coupler's ability to tune the antenna.

T.O. 31R2-2URC-111

2-8. CHECKING THE INSTALLATION. After the 100/500 Watt Antenna Coupler has been installed and interconnection cables are connected, verify that each item in the list below has been completed before applying power:

- a. All connectors are attached and tight.
- b. Ground wires are connected between the 100/500 Watt Antenna Coupler and a known good ground. Examples of good grounds are a cold water pipe, a long copper stake pounded into solid earth, or a system ground bus at an

existing site. A good ground must be 10 ohms or less.

- c. Hardware for the equipment is securely tightened.
- d. The antenna is in place, correctly connected, and protected against accidental contact.

After considering each item on the list above, the equipment may be considered ready for the application of power. Power application and initial equipment testing are discussed in chapter 3.

Table 2-1. Interconnection Cabling Information

W1P1 RF Input (Coaxial)		
Mating connector:		
M39012/01-0005		
Cable type: RG-8/U or RG-213		
A3P1 Control (Coupler end)		J5 Control (Transceiver end)
Mating connector: MS39012/01-0005		Mating connector: MS3106A20-27P
J1-A	Ground	J5-A
J1-B	Key (OV=Keyed)	J5-B
J1-C	Fault (OV=Fault)	J5-C
J1-D	Ground	J5-D
J1-E	Tune Pulse (OV=Tune Request)	J5-E
J1-F	Tune Power Request (OV=Request)	J5-F
J1-G	Bypass (OV=Bypass)	J5-G
J1-H	+13.6 VDC	J5-H
J1-I	+13.6 VDC	J5-I
J1-J	Key Disable (OV=Disable)	J5-J
J1-K	LPA ID	J5-K
J1-L	Not Used	J5-L (+ 115V AC)
J1-M	Not Used	J5-M (115V AC neutral)
J1-N	Thermal Fault (OV=Fault)	J5-N
E1 RF Output (Terminal Connection)		

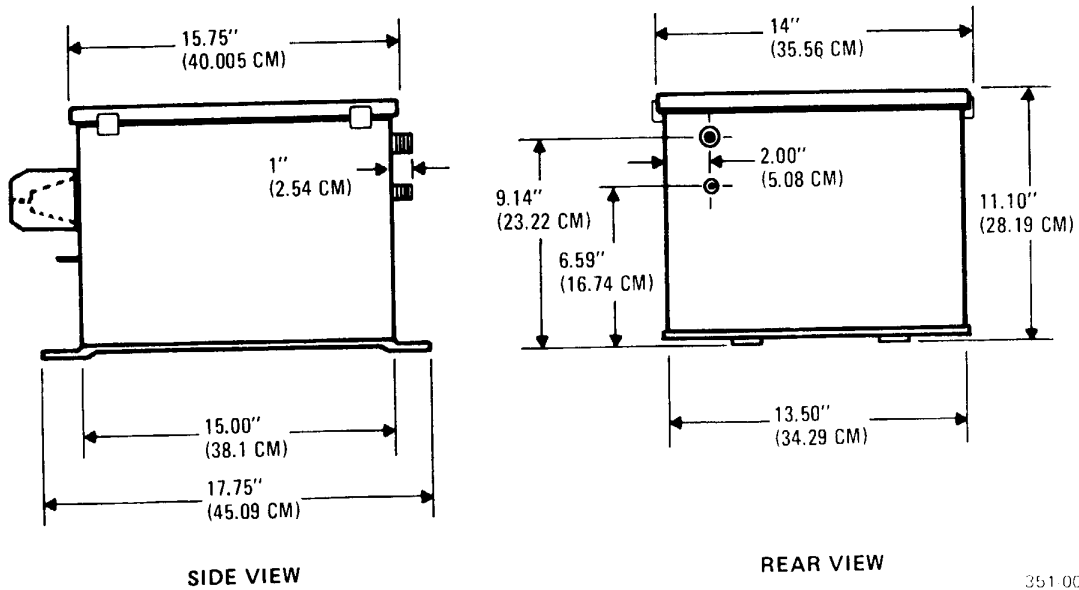
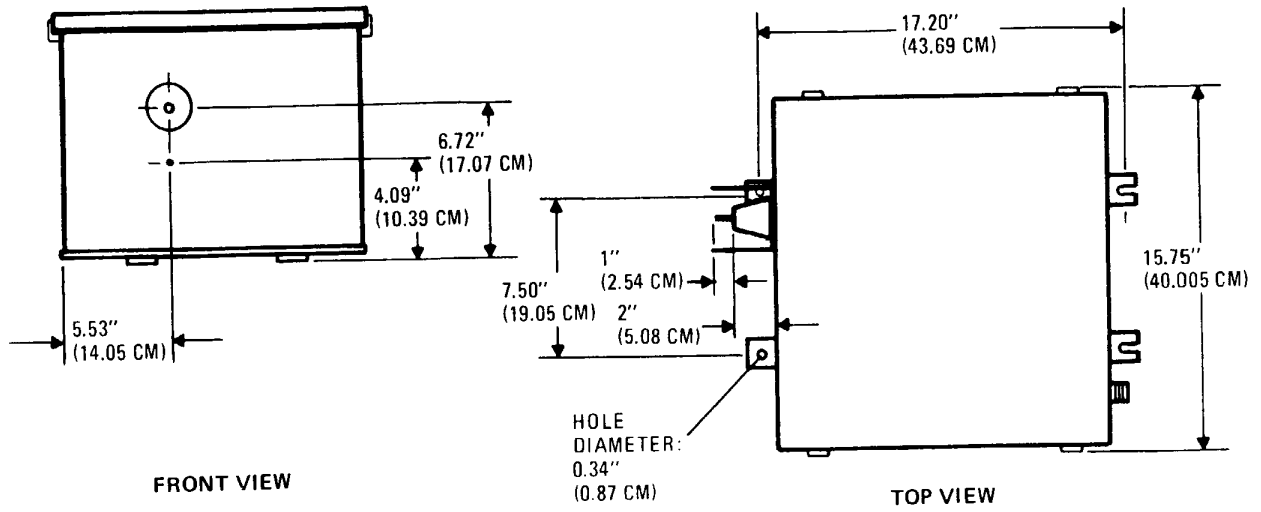

351 009

Figure 2-5. 100/500 Watt Antenna Coupler Dimensions

STEP

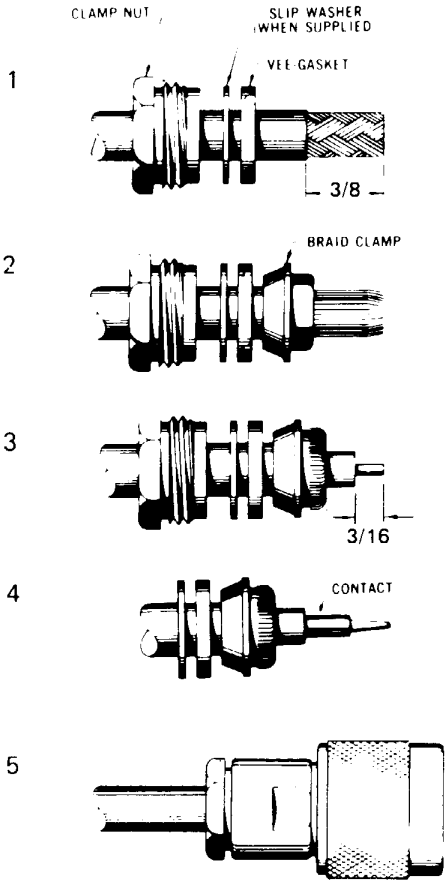

Cut cable end square, place clamp-nut, slip washer (when supplied), and gasket over jacket. Remove 3/8" of vinyl jacket.

Place braid clamp over braid against jacket cut. Comb out copper braid as shown.

Fold braid back over braid clamp and trim as shown. Cut off dielectric 3/16" from end. Tin center conductor.

Solder contact to center conductor. Avoid use of excessive heat. See that end of dielectric is clean. Contact must be flush against dielectric. Outside of contact must be free of solder.

Thread assembly into connector, and lock securely. Vee gasket must be split by braid clamp.

350-009

Figure 2-6. RF Input/Output Cable W1, Fabrication Detail

STEP

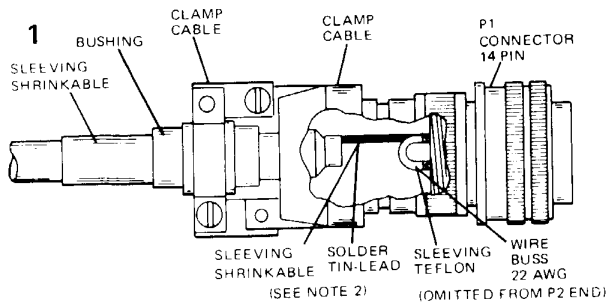

1. In Item 1, cable, clip off unused leads; yellow, violet, green, white/green, white/blue and white/yellow.
2. Twist four carriers of shield together (approximate 28 wires) and shrink Item 6 over them.

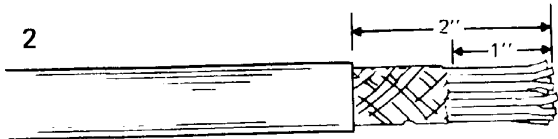

Remove 2" of vinyl jacket from cable as shown. Do not cut into shielding. Remove 1" of shielding as shown. Take care not to damage insulation on wires in cable bundle.

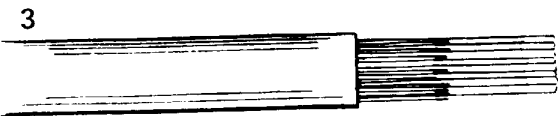

Carefully comb out shield wires as shown.

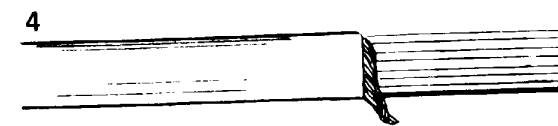

Make a part in the combed shield wires opposite the black wire in the cable. Pull the shield wires around both sides of the cable and twist together to make a pigtail as shown.



Remove 1/2" of insulation from a 2-1/2" length of No. 22 black stranded wire and tin.

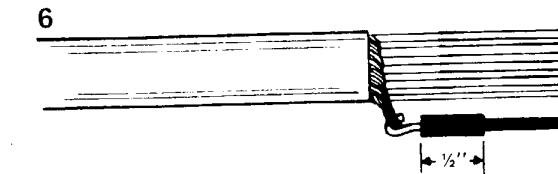

Twist the stripped end of black wire with the pigtail and solder. Cut 1/2" black shrink sleeving and install over soldered connection. Use a heat gun (an alternative is an open flame) to shrink sleeving exercising caution to avoid getting heat onto cable jacketed.

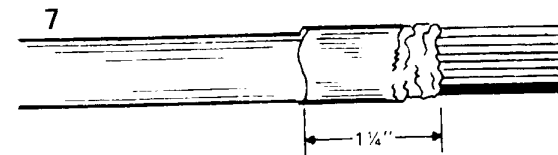

Install shrink sleeving over cable as shown -- apply heat and "shrink" in place. Use heat gun. If no heat gun is available use open flame. Avoid getting heat on cable jacket. Rotate cable for an even shrinkage.

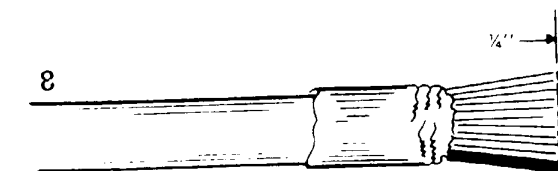

Remove 1/4" insulation from wires to be used

351-007

Figure 2-7. Dc Power and Control Cable W2, Fabrication Detail

STEP

9.

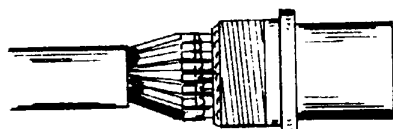

Refer to Table 2-1 for interface connections. Twist and tin stripped wires together to form pairs as shown for cable lengths over 100 feet (30 meters). Twist and tin remaining stripped wires. Cut sleeving supplied in connector kits into 1/2 inch (1 1/4 cm) lengths and slide over each wire. Keep wires parallel as they come out of the cable bundle to the connector pins. Ensure the black wire installed in step 6 and the black wire in the cable are lined up with and soldered to pin D. Solder wires to the solder cups using Table 2-1. Slide sleeving over solder cups. Write down wire colors assigned to each pin number for reference when assembling the connector on the other end of the cable.

10.

Repeat assembly and soldering procedures for the other end of the cable.

11.

Check both ends of the cable for continuity, shorts between wires and shorts to the connector shell.

12.

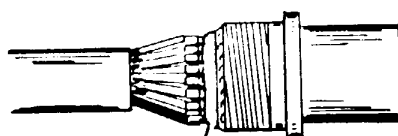

RTV TYPE SILASTIC RUBBER

CAUTION

Care should be taken to not mix up pin J1-L with pin J1-N, which are closely adjacent to each other and can be easily misidentified.

Apply RTV type silastic rubber (supplied in RF-281 Accessory Kit) to a thickness of approximately 1/8 inch. Use small opening of nozzle to insure getting rubber between all solder cups. Use small, slender object such as a piece of wire or toothpick to insure a smooth, continuous waterseal.

13.

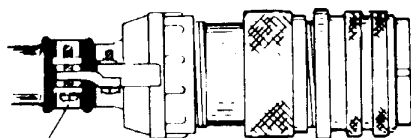

CABLE CLAMP AND RUBBER INSERT

Assemble the plug as shown. Assemble clamp as tightly as possible onto the shell to assure a watertight connection around the cable. Repeat watersealing and assembling of connector on other end of cable. After connector has been threaded onto Antenna Coupler case connector J2, wrap both connectors with several layers of plastic electrical tape as close to the Antenna Coupler case as possible. (For protection against corrosion of mating threads in wet or humid environments.)

NOTE: To convert inches to centimeters, multiply by 2.540.

350-008

Figure 2-8. Dc Power and Control Cable W2, Fabrication Detail

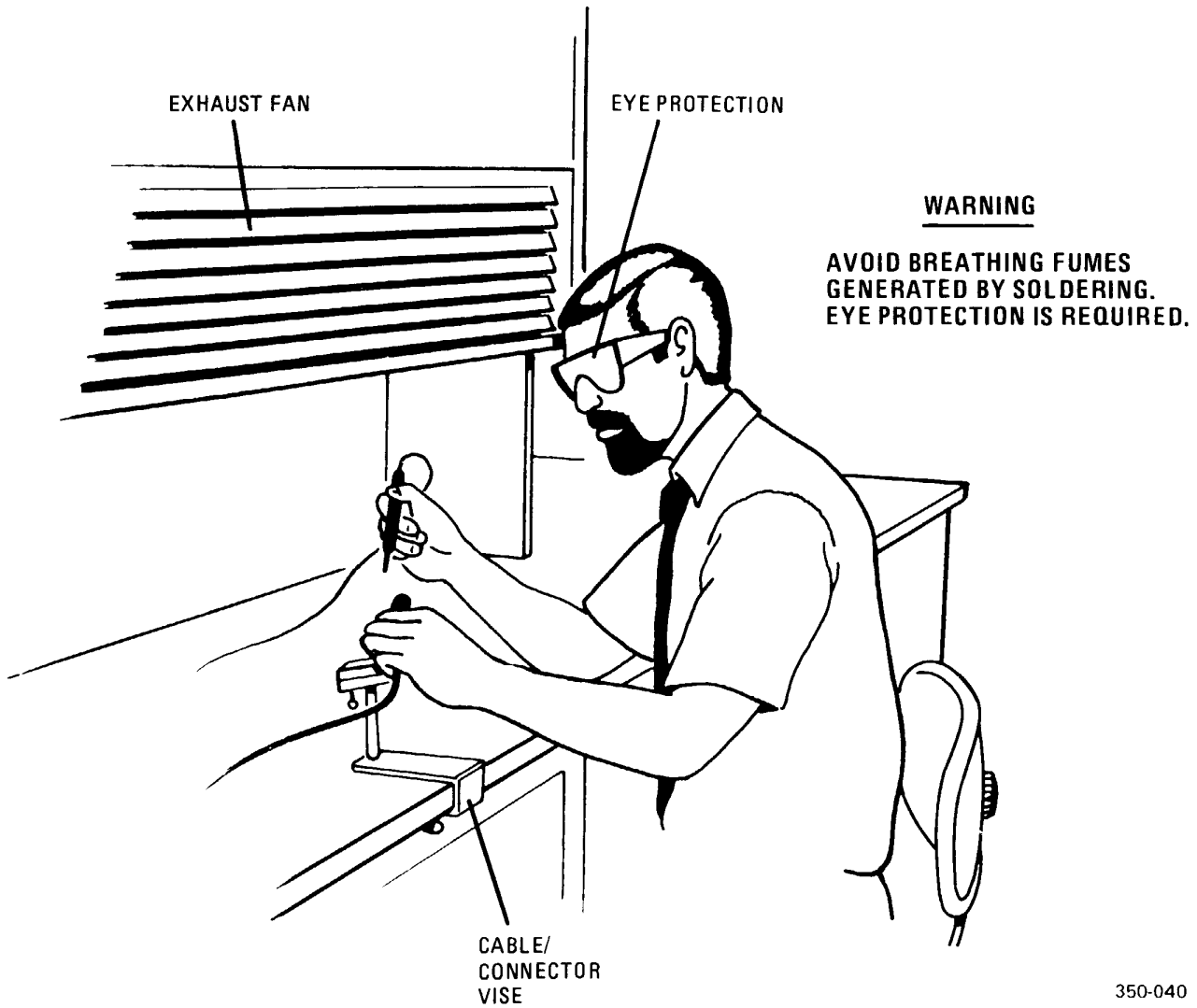

Figure 2-9. Safety Precautions for Fabrication of Cables

CHAPTER 3

PREPARATION FOR USE AND RESHIPMENT

Section I. PREPARATION FOR USE

3-1. INITIAL CONTROL SETTINGS. The 100/500 Watt Antenna Coupler does not have any external controls. All control of the 100/500 Watt Antenna Coupler is effected from the front panel of the associated 100 Watt Transceiver or from the front panel of an associated remote control unit, if used.

3-2. INITIAL POWER APPLICATION. The 100/500 Watt Antenna Coupler receives input power from the 100 Watt Transceiver. The power switch on the 100 Watt Transceiver front panel also controls power to the 100/500 Watt Antenna Coupler. Upon completion of the steps listed below, the operator will have confirmed that the 100/500 Watt Antenna Coupler is ready for the checkout test procedure given in paragraph 3-4.

3-3. STEP-BY-STEP SEQUENCE FOR INITIAL POWER APPLICATION.

- a. Complete any pre-power application checks for the associated 100 Watt Transceiver as indicated in T.O. 31R2-2URC-81, chapter 3 (On-equipment manual).
- b. Place 100 Watt Transceiver power switch to the POWER ON position.
- c. The primary power to the 100/500 Watt Antenna Coupler is protected by current limiting and overvoltage circuits. However, if there are any abnormal indications, remove power (at the 100 Watt Transceiver) until the problem has been corrected. No BIT fault indication from the 100/500 Watt Antenna Coupler is displayed on the 100 Watt Transceiver FREQUENCY display until the after the 100/500 Watt Antenna Coupler is instructed to TUNE to a frequency.

- d. Proceed to Initial Checkout procedure.

3-4. INITIAL CHECKOUT. In the initial checkout sequence, the 100/500 Watt Antenna Coupler is checked for readiness through the use of the normal front panel controls on the associated 100 Watt Transceiver. The checkout procedure provided below should be conducted after performing the initial power application procedure in paragraph 3-2.

3-5. STEP-BY-STEP SEQUENCE FOR CHECKOUT

- a. Select an unmodulated carrier mode (CW or AM) at the 100 Watt Transceiver.
- b. Tune the associated 100 Watt Transceiver to a specific operating frequency using instructions in the Receiver-Transmitter, Radio T.O. 31R2-2URC-81 On-equipment instruction manual.
- c. Momentarily key the unit. The 100/500 Watt Antenna Coupler can be heard driving to the tuned position. If the 100/500 Watt Antenna Coupler does not drive at all, a problem exists in the 100/500 Watt Antenna Coupler servo loop.
- d. If the 100/500 Watt Antenna Coupler will not tune, a FAULT will be displayed on the associated 100 Watt Transceiver.
- e. If no faults appear, then the 100/500 Watt Antenna Coupler can be considered operational. If fault indications occur, refer to the BIT Fault Interpretation table in chapter 6 of the technical order for the 100 Watt Transceiver.

Section II. PREPARATION FOR RESHIPMENT

3-6. PREPARATION FOR RESHIPMENT.

3-7. STEP-BY-STEP DISASSEMBLY PROCEDURE.

- a. Ensure that all power sources associated with the 100/500 Watt Antenna Coupler are shut down.
- b. Disconnect all interface cables and grounding straps from the 100/500 Watt Antenna Coupler.
- c. Replace dust cover caps over 100/500 Watt Antenna Coupler connectors.
- d. Unbolt mounting hardware and remove 100/500

Watt Antenna Coupler from its mounting. Retain mounting hardware for future installation.

3-8. STEP-BY-STEP PACKING AND CRATING PROCEDURE.

- a. Refer to figure 2-1. Repackage all of the interface cables and mounting hardware associated with the 100/500 Watt Antenna Coupler in the original (or an equivalent) container.
- b. Place the ancillary cables and mounting hardware into the container along with the 100/500 Watt Antenna Coupler.
- c. Close and bind the container.

CHAPTER 4

OPERATION

Section I. CONTROLS AND INDICATORS

4-1. INTRODUCTION. The 100/500 Watt Antenna Coupler has no external operating controls or indicators. Its operation is automatically performed upon initiation of control signals from the associated 100 Watt Transceiver. If there is any reason to suspect a problem in the 100/500 Watt Antenna Coupler, refer to the 100 Watt Transceiver On-equipment instruction manual, T.O. 31R2-2URC-81, chapter 6, section I, and initiate the BIT test sequence.

4-2. INDICATIONS OF NORMAL OPERATION.

a. Homing. When the frequency is changed at the 100 Watt Transceiver or at the remote control unit, and the transceiver is keyed, the 100/500 Watt Antenna Coupler servos can be heard driving to the HOME positions. If the 100/500 Watt Antenna Coupler has not reached the HOME position, or does

not drive at all, a problem may exist in the 100/500 Watt Antenna Coupler or in the interface between the 100 Watt Transceiver and the 100/500 Watt Antenna Coupler.

b. Bypass. When the 100/500 Watt Antenna Coupler bypass condition is initiated, the 100/500 Watt Antenna Coupler rf signal is switched from the tune path to the bypass path so that the receiver is still operational or so that transmitted signals will still reach the antenna in the event of a coupler failure.

c. Relation to 100 Watt Transceiver Operation. Refer to chapter 4, section 1 of the 100 Watt Transceiver On-equipment instruction manual, T.O. 31R2-2URC-81, for frequency and key display operation instructions that will indicate the status of the 100/500 Watt Antenna Coupler.

Section II. OPERATING INSTRUCTIONS

4-3. INTRODUCTION. Refer to chapter 4, section 2 of the 100 Watt Transceiver instruction manual, T.O. 31R2-2URC-81, for frequency change

and operating instructions that will initiate automatic operation of the 100/500 Watt Antenna Coupler.

CHAPTER 5

THEORY OF OPERATION

Section I. GENERAL INFORMATION

5-1. INTRODUCTION. Figure 1-2 is a simplified functional block diagram of the 100/500 Watt Antenna Coupler. For the following discussions, refer to FO-1, the detailed 100/500 Watt Antenna Coupler functional block diagram (Chapter 8 of this manual), the 100/500 Watt Antenna Coupler schematic diagram (Depot Manual), and the Logic PWB schematic diagram (Depot Manual). FO-1 includes, in simplified form, the functions of the Logic PWB Assembly A1.

5-2. FUNCTIONAL OPERATION AND SIGNAL FLOW OF RF CIRCUITS. The 100/500 Watt Antenna Coupler matches the output impedance of the 100 Watt Transceiver or the output of the 500 Watt Linear Power Amplifier to an antenna. The 100/500 Watt Antenna Coupler is fully automatic and includes all network tuning and monitoring functions. Matching between the antenna and the rf source must result in a voltage standing wave ratio of 1.2:1 or less before the 100/500 Watt Antenna Coupler allows full power transmitter keying. However, both transmission and reception can take place in an untuned condition with the tuning circuits bypassed.

a. RF Path Signal Flow. The 100 - 500 Watt rf input is routed from the RF INPUT plug P1 to the RF PWB Assembly A1A1, which incorporates two functional elements: (1) the discriminator sampling circuit and (2) the bypass relay circuit. The discriminator sampling circuit contains four voltage samplers (C1, C2, C3, and C4) and one current sampler (T1). All sampled signals are routed to the discriminator circuit on the A1 Logic PWB Assembly where they are detected to obtain control signals for the automatic tuning sequence. In bypass operation, the rf circuits may be untuned and are bypassed. The rf input is routed through normally closed contacts of bypass relays A1A1K1 and A2K2 (A2K2 is located on the Lower Shelf Assembly) to antenna terminal E1. When the 100/500 Watt Antenna Coupler is tuned, the rf signal is routed through the discriminator sampling circuit,

the normally open contacts of bypass relay A1A1K1, and impedance matching transformer A1A1T2 to the main tuning elements A2C1 and A2L1 on the A2 Lower Shelf Assembly. The RF signal then passes through the normally closed contacts of relay A2K1 and the normally open contacts of relay A2K2 to the antenna output terminal E1.

b. Transformer A1A1T2. Transformer A1A1T2 matches the standard 50-ohm output impedance of the 100 Watt Transceiver or the 500 Watt LPA to the 12.5 ohm operating impedance of the 100/500 Watt Antenna Coupler system. Transformer A1A1T2 has a turns ratio of 2:1 (an impedance ratio of 4:1) and thus serves to match the optimum 12.5 ohm 100/500 Watt Antenna Coupler system impedance to the standard 50-ohm transmitter output.

c. Main Tuning Elements. Vacuum variable capacitor A2C1 and variable inductor A2L1, the main tuning elements in the rf path, are located on the Lower Shelf Assembly. They are driven by separate servo systems to automatically tune to the antenna impedance. One output of the discriminator drives the capacitor servo system and a second output drives the inductor servo system. If the jumper on the Logic PWB Assembly is in the WHIP (J9) position, long wire adapter capacitors are bypassed (shorted) through the contacts of relay A2K1 unless the 100/500 Watt Antenna Coupler fails to tune successfully on the first attempt. In such a case, relay A2K1 operates, placing the capacitors in the rf signal path, and a second attempt is made to achieve the tuned condition. If the jumper on the Logic PWB Assembly is in the LONG WIRE (J10) position, then the long wire adapter capacitors are in the rf signal path unless the coupler fails to tune successfully on the first attempt. In such a case, relay A2K1 deenergizes, bypassing the capacitors in the rf signal path. Then, a second attempt is made to achieve the tuned condition.

d. Receive RF Signal.

T.O. 31R2-2URC-111

(1) If the 100/500W Antenna Coupler is tuned for a specific frequency, the receive rf signal is routed through the tuned path. The receive rf signal enters the 100/500 Watt Antenna Coupler through E1 and is routed through the normally open contacts of bypass relay A2K2 to either long wire adapter capacitors or to the contacts of the long wire bypass relay A2K1. The signal is then routed through the tuned circuit of A2C1 and A2L1 to the A1A1E1 connector on A1A1 RF PWB Assembly, and through impedance matching transformer A1A1T2, bypass relay A1A1K1, and the discriminator sampling circuit to connector W1P1.

(2) If the 100/500W Antenna Coupler is not tuned, a receive rf signal input from the antenna is routed through the bypass portion of A2K2, relays A2K1 and A1A1K1, and through the discriminator sampling circuit to connector W1P1.

5-3. FUNCTIONAL OPERATION OF A1 LOGIC PWB ASSEMBLY CIRCUITS. The control logic circuitry on Logic PWB Assembly A1 monitors logic control signals from the 100 Watt Transceiver and the detected VSWR, phase error and load error signals from the discriminator. The logic circuits produce an appropriate sequence of responses required to provide automatic operation. The individual functional block diagrams included in FO-1 summarize the logic elements required to generate these functions. Detailed circuit descriptions are included in section II of this chapter.

a. TUNE PULSE Signal. The sequence of events begins in the 100/500 Watt Antenna Coupler with either the initial application of power or upon receipt of a TUNE PULSE signal from the 100 Watt Transceiver. Either of these conditions generates a TUNE 1 PULSE signal, which resets all of the flip-flop latches in the 100/500 Watt Antenna Coupler control logic circuits. RF transmission is initially inhibited. The 100/500 Watt Antenna Coupler must send the 100 Watt Transceiver a TUNE PWR REQUEST signal before rf will be sent to the 100/500 Watt Antenna Coupler to allow tuning. When the TUNE PULSE is received, the 100/500 Watt Antenna Coupler starts its Homing Mode. The servo amplifiers are enabled, causing variable capacitor A2C1 and variable inductor A2L1 to drive toward the HOME positions of maximum capacitance and minimum inductance.

b. TUNE PWR REQUEST Signal. When the tuning

elements reach the HOME positions, the transmitter key circuit is enabled. The RF PRESENT latch in the 100/500 Watt Antenna Coupler, the Tune 1/Tune flip-flop, and the timer fault circuit are reset. A TUNE PWR REQUEST signal is generated and sent to the 100 Watt Transceiver. The 100 Watt Transceiver responds by supplying the 100/500 Watt Antenna Coupler with a low power rf signal. The servo circuits are enabled, allowing A2C1 and A2L1 to tune in accordance with LOAD and PHASE errors sensed by the discriminator. If a VSWR of less than 1.2:1 is obtained, the 100/500 Watt Antenna Coupler is fully tuned and ready for handling full rf power. If the time limit of 10 seconds is not met, or if A2L1 is driven to maximum inductance, the tuning process is interrupted, A2L1 and A2C1 are sent back to their home positions, and the tuning sequence is started over with the long wire adapter capacitor inserted in the rf path (if the jumper is in the WHIP or J9 position) or removed (if the jumper is in the LONG WIRE or J10 position).

c. TUNED Latch. When the tuned condition is achieved, the TUNED latch is set, the TUNE PWR REQUEST signal is removed, and a 100/500 Watt Antenna Coupler READY signal is generated. The timer fault circuit is disabled, the keyline (GND) is released by the keyhold circuit and the servo amplifiers are disabled. A KEY DISABLE signal is removed, allowing the 100 Watt Transceiver to transmit at full power. The 100/500 Watt Antenna Coupler is then ready to handle full power transmitting. During transmission, the 100/500 Watt Antenna Coupler will automatically correct for small changes in impedance if the VSWR becomes greater than 2:1.

5-4. FUNCTIONAL OPERATION AND SIGNAL FLOW OF LOWER SHELF ASSEMBLY A2 CIRCUITS. The rf path in Lower Shelf Assembly A2 is described in paragraph 5-3.b. Servo Driver Assembly A2A1 contains the two servo motors and limit switches that control positioning of vacuum variable capacitor A2C1 and variable inductor A2L1. Automatic braking is built into the servo system so that if the motors are not driving they are braking. This action prevents overshoot in the tuning system. All control signals to or from the servo system, the long-wire adapter relay, or the bypass relay interface directly with the Logic PWB Assembly A2A1.

Section II. 100/500 WATT ANTENNA COUPLER CIRCUIT THEORY

NOTE

The following discussion assumes that the jumper on the Logic PWB Assembly is in the WHIP (J9) position.

* Indicates that the signal is active low. On schematic diagrams, active low signals have a bar over the top.

5-5. DISCRIMINATOR CIRCUITS. Before the antenna has been tuned or matched by the reactive elements in the 100/500 Watt Antenna Coupler, the 100/500 Watt Antenna Coupler will present to the Transmitter an impedance other than 50 ohms, and the impedance will be either inductive or capacitive. The function of the discriminator is to sense the reactive component of the rf signal and to provide proportional dc outputs (PHASE ERROR and LOAD ERROR) to the servo system to drive the variable inductor and capacitor in the directions required to achieve a 50-ohm resistive load condition. In addition, the discriminator provides outputs that indicate the presence of rf (RF ON) and indicate when the VSWR is too high for transmitting ($VSWR > 2:1$) and when the tuned condition is achieved ($VSWR < 1.2:1$). The inputs to the discriminator circuit come from the four voltage samplers (C1, C2, C3, and C4) and one current sampler (T1) on RF PWB Assembly A1A1. The output of transformer T1 is applied to R66 and R67. A voltage drop proportional to the sampled current is developed across the two resistors. This voltage is detected by forward power detector CR42 and reflected power detector CR41.

5-6. REFLECTED POWER DETECTOR. The detected output of CR41 is added to the voltage that appears across the divider network consisting of A1A1C1, A1C29 and A1C31. The phasing of the voltage across R66 and the voltage divider capacitors A1A1C1, A1C29, and A1C30 makes the output detected by CR41 a representation of reflected power. The detected output voltage of CR41 is applied to the (+) input of operational amplifier U7-5, which is the reflected power buffer amplifier. Diode CR50 and resistor R91 are connected to U7-5 to correct for temperature variations in reflected power detector CR41. The two diodes have identical characteristics. CR50 is biased in the opposite direction from CR41 so that any variation applied to the U7-5 input by CR41 will be compensated by an opposite variation across CR50. Since CR41 is

biased on by a -10 Vdc across R88 and CR50 is biased on by a +10 Vdc across R91, the voltage level at U7-5 is zero. This allows for precise detection at low signal levels. Resistors R89 and R90 provide a summing point for the voltages across the two diodes.

5-7. FORWARD POWER DETECTOR. The detected output of CR42 is added to the voltage which appears across the divider network consisting of A1A1C2 and A1C30. The phasing of the voltage across R67 and voltage divider capacitors A1A1C2 and A1C30 makes the CR42 detected output a representation of forward power. The detected output voltage of CR42 is applied to the (+) input of operational amplifier U7-3, which is the forward power buffer amplifier. Diode CR49 and resistor R82 are connected to U7-3 to correct for temperature variations in forward power detector CR42. CR49 and CR42 have identical characteristics and are oppositely biased so that any variation applied to the U7-3 input by CR42 will be subtracted by an opposite variation across CR49. Since CR42 is biased on by a -10 Vdc across R79 and CR49 is biased on by a +10 Vdc across R82, the voltage level at U7-3 is zero. This allows for precise detection at low signal levels. Resistors R80 and R81 provide a summing point for the voltages across the two diodes.

5-8. RF ON THRESHOLD DETECTOR. The U7-1 output of the forward power buffer is applied to the U10-5 input of the RF On threshold detector. The threshold is set by resistors R94 and R95 at the equivalent of an rf level of 10 watts. When the threshold is exceeded, a logic high is produced at the U10-7 output, called RF ON, which indicates there is sufficient rf to begin tuning.

5-9. 2:1 VSWR THRESHOLD DETECTOR. The output of the forward power buffer amplifier U7-1 is applied to input of the 2:1 VSWR threshold detector at U8-3. The output of reflected power buffer at U7-7 is applied to the U8-2 input of the detector.

T.O. 31R2-2URC-111

The detector is operated at full gain and its threshold is determined by resistors R85, R86, and R87. The values of R85, R86, and R87 are chosen to set the threshold of U8 at a forward-to-reflected voltage ratio of 2:1. As long as the threshold is not exceeded ($U8-2 < U8-3$), a logic high is produced at U8-1, called the VSWR $<2:1$ signal. (The signal is used in negative logic.)

5-10. 1.2:1 VSWR THRESHOLD DETECTOR. The output of the reflected power buffer amplifier at U7-7 is applied to the input of 1.2:1 VSWR threshold detector at U8-5. The output of the forward power buffer at U7-1 is applied through the divider of R85, R86, and R87 to the U8-6 input of the detector. The detector is also operated at full gain and its threshold is also determined by resistors R85, R86, and R87. The threshold is set at a forward-to-reflected voltage ratio of 1.2:1. When the threshold is exceeded ($U8-5 > U8-6$), a logic high is produced at the U8-7, called the VSWR $>1.2:1$ signal.

5-11. PHASE ERROR DETECTOR. Diodes CR43, CR44, CR45, and CR46 detect the current transformer voltage developed across resistors R66 and R67. The detected output of these diodes is vector-summed to the voltage which appears across the divider network consisting of A1A1C3, A1R68 and A1R69. Capacitors C34 and C35 are rf coupling capacitors that allow the full voltage to be applied to the detectors. The vector sum voltage is the PHASE ERROR signal. It is tapped off the PHASE ERROR ADJUST potentiometer R71 and applied to the U6-5 input of the phase detector amplifier. The amplified PHASE ERROR signal from U6-7 is applied to the input of the servo amplifier circuit that drives tuning capacitor A2C1.

5-12. LOAD ERROR DETECTOR. Diodes CR47 and CR48 are load detectors. CR47 detects the voltage developed across R66 while CR48 detects the voltage at voltage divider A1A1C4, A1C36 and A1C37. Capacitor C36 is a variable capacitor which permits adjustment of the LOAD ERROR signal. The signal is summed by resistors R76 and R77 and applied to the U10-3 input of the load detector amplifier. The gain of amplifier U10-1/2/3 is controlled by resistors R104 and R106. The amplified LOAD ERROR signal from U10-1 is applied to the input of the servo amplifier circuit that drives tuning inductor A2L1.

5-13 CONTROL LOGIC. Refer to the Control Logic PWB schematic diagram (Depot Manual) for the

following circuit descriptions.

NOTE

The logic circuits in the 100/500 Watt Antenna Coupler use negative logic (NAND and NOR gates). Some of the control signals use low logic levels for the active signal states. This is shown on the schematic diagrams by a bar drawn over the signal names and by the inverting symbol on the gate outputs. A NAND gate with low active inputs works in the same way that an OR gate would work with high active inputs. Also, a NOR gate with low active inputs works in the same way that an AND gate would work with high active inputs.

5-14. TUNING SEQUENCE CONTROL. Logic PWB Assembly A1 operates in two basic modes: Tune 1 and Tune 2. Tune 1 occurs first in the tuning sequence and is followed by Tune 2 only if correct tuning is not achieved in the Tune 1 mode. The difference between the two modes is that in the Tune 2 mode, a compensating capacitor for long wire antennas (A2A3C1) is inserted in the rf path. When the 100/500 Watt Antenna Coupler receives a TUNE PULSE signal, either from the 100 Watt Transceiver or from its own power-up TUNE PULSE generator, all of the 100/500 Watt Antenna Coupler latches (Home, Ready, RF Present, Fault, and Tune 1/Tune 2) become reset. The 100/500 Watt Antenna Coupler tuning elements then drive to the Home positions and try to tune to the antenna in the Tune 1 mode, using the PHASE ERROR and LOAD ERROR signals to control tuning. If a fault occurs during the Tune 1 mode, either a Tune Time Fault or a Max L Fault (motor driving A2L1 until it reaches the end stop), the 100/500 Watt Antenna Coupler will automatically rehome and go into the Tune 2 mode. If a fault should occur during the Tune 2 mode, the 100/500 Watt Antenna Coupler will report the fault to the 100 Watt Transceiver (TUNE TIME fault) and stop tuning. If a fault occurs, the 100/500 Watt Antenna Coupler must receive a new TUNE PULSE from the 100 Watt Transceiver before it will start tuning again. During tuning, the 100/500 Watt Antenna Coupler controls transmitter keying. Until homing occurs, transmitter keying is prevented. After the 100/500 Watt Antenna Coupler tuning elements have homed, the Transmitter is allowed to operate at partial power (approximately 40 watts). When a VSWR of less than

1.2:1 has been achieved after tuning, keying at full power can take place.

a. TUNE PULSE* Stretching. The TUNE PULSE* signal enters the 100/500 Watt Antenna Coupler on connector A1J4-1 and is applied to NAND gate A1U15, pins 12 and 9. The negative pulse on U15-12 is inverted and appears at the output of U15-11 as a positive-going pulse. The positive-going TUNE PULSE is applied to a pulse stretching network (R29, R30, C12, and CR17) and to inverter gates U16-9/10 and U16-11/12. The stretched pulse keeps the latches in the set condition long enough so that they do not interfere with each other. The output of NAND gate U15-10 is also applied to a pulse stretching network (R52, R53, C22, and CR36) and to inverter gates U16-5/4 and U16-3/2 for the same reason.

b. Power-Up Reset Pulse Generator. The input circuit of gates U15-8 and 13 includes a power-up reset pulse generator consisting of R26, R28, C14, and CR15. This circuit automatically furnishes a TUNE PULSE* when power is applied, resetting the latches (Home, Ready, RF Present, Fault, and TUNE1/TUNE 2). Then, the 100/500 Watt Antenna Coupler will be ready to initiate a tune cycle.

5-15. TUNE 1/TUNE 2 ELEMENTS. The Tune 1/Tune 2 circuit is used to control 100/500 Watt Antenna Coupler tuning in the Tune 1 mode or the Tune 2 mode. When the 100/500 Watt Antenna Coupler is initially turned on or when it receives a TUNE PULSE* from the 100 Watt Transceiver, the Tune 1/Tune 2 flip-flop is preset to the Tune 1 condition and all four latches (Home, Ready, Fault and RF Present) are reset. The positive-going output at U16-2 is applied to U19-1. This causes the output at U19-3 to go low and the output at U19-4 to go high, indicating a Tune 1 condition. With the U19-3 output low, the long wire adapter capacitor relay is deenergized.

(1) The U19-4 output is connected to the fault circuit at U19-9. As long as the signal at U19-9 is high, indicating a Tune 1 condition, no fault will be reported to the 100 Watt Transceiver. If variable inductor A2L1 reaches its MAX L limit during the Tune 1 mode, the MAX L* signal at U11-7 will go low. This will produce a high at U11-6, which is applied across diode CR34 to the reset input of Tune 1/Tune 2 flip-flop U19-6. Also connected to the U19-6 reset input, across diode CR35, is the U15-4 output of the Tune Time Fault flip-flop. Any time there is a Tune Time Fault, the U15-4 output will go high and reset the Tune 1/Tune 2 flip-

flop. This causes the U19-3 output to go high and the U19-4 output to go low, indicating a Tune 2 condition.

(2) When the Tune 1/Tune 2 flip-flop changes to the Tune 2 state, the positive-going TUNE 2 PULSE at U19-3 is capacitively coupled by C23 to inverter U16-7/6, where the pulse is inverted to a negative-going pulse. The output of U16-6 is then applied to U15-13, but not to U15-8 because the negative-going pulse is blocked by diode CR15. The TUNE 2 PULSE resets only the Homing flip-flop, the Ready flip-flop, and the Fault flip-flop. The Tune 2 mode causes the 100/500 Watt Antenna Coupler tuning elements to Home again and clears any fault that has occurred. Because of the U19-8,-9,-10 NOR gate, no faults that occur during Tune 1 operation are passed on to the 100 Watt Transceiver. However, any fault that occurs in the Tune 2 mode is reported to the 100 Watt Transceiver.

(3) The RF Present flip-flop is not reset by the TUNE 2 PULSE so that the 100/500 Watt Antenna Coupler continues to try to tune without interruption during the whole Tune 1/ Tune 2 sequence.

5-16. BYPASS RELAY CONTROL. Part of U9 is used as the bypass relay latch to prevent hot switching of the two bypass relays in the 100/500 Watt Antenna Coupler. Should a bypass condition be required for any reason, a high occurs at U9-14. If it is present, the bypass condition is inhibited and the output at U9-15 prevents the bypass relays from operating.

a. Bypass Relay CLOCK Signal. The bypass relay CLOCK signal at U9-5 clocks the BYPASS signal into the bypass relay latch. A high on the CLOCK input line causes U9 to LATCH (not allowing data at U9-14 to pass to U9-1), while a low causes U9 to UNLATCH (allowing data at U9-14 to be at U9-1). The generation of the bypass relay CLOCK signal begins at the relay control latch circuit U22. U22 is a 2-input NAND gate; pin 2 receives the KEY signal input from the 100 Watt Transceiver and pin 1 receives the RF PRESENT signal generated in the RF Threshold Detector U10. As long as both the KEY signal and the RF ON signal are high, a low latch signal is generated at pin 3 of U22, causing a high latch signal at U16-15 and the U9-5 clock input, latching U9 and preventing the Bypass Relay from changing state. If either of the two input signals should go low, the output signal at U22-3 goes high, signaling an UNLATCH condition, allowing data to be clocked through U9 and allowing the

T.O. 31R2-2URC-111

Bypass Relay to operate if the bypass signal is present.

b. BYPASS Signal. The BYPASS signal at U9-14 is supplied either by the 100 Watt Transceiver or generated at one of several places on the A1 Logic PWB Assembly. The locally generated BYPASS signals are applied through an OR gate, consisting of diodes CR10, CR11, and CR78, to the latch input. The BYPASS signal from the 100 Watt Transceiver is applied as ground through connector J4-15 to the cathode of diode CR7. Diode CR7 is connected to a pullup circuit on the input of inverter U11-3. Because of the pullup circuit the output at U11-2 will normally be held low, a no-bypass condition. When the ground signal from the 100 Watt Transceiver is applied to the cathode of CR7, the signal input at pin 3 of U11 is also pulled low. This allows the output at pin 2 of U11 to go high, forcing a bypass condition. Only the bypass signal from the 100 Watt Transceiver is applied to pin 2 of NOR gate U18. This is done so that whenever a bypass is requested from the 100 Watt Transceiver, the servos are disabled. The other bypass signals generated on Logic Control PWB Assembly A1 are prevented from disabling the servos by steering diode CR9. The BYPASS signal across diode CR11 is generated by the RF PRESENT signal output of RF Present flip-flop U13-10. This signal is high after a TUNE PULSE* and when no rf is present. This places the antenna coupler in Bypass while the coupler is homing and before the tune cycle starts. The BYPASS signal across diode CR10 is generated at NOR gate U19-10 whenever an 100/500 Watt Antenna Coupler FAULT occurs in the the Tune 2 Mode. The BYPASS signal across diode CR78 is generated at NAND gate U20-10 whenever there is a THERMAL FAULT. Any one of these BYPASS signals will place a high logic level at the bypass relay latch input U9-14. This input, along with the low bypass relay CLOCK signal, will remove the positive voltage level at U9-15, which turns off driver transistor switch Q12 and removes the positive voltage from the base of Q13 and Q14. The ground is removed from bypass relays A1A1K1 and A2K2, deenergizing them. The ground is also removed from Q11, thus turning it on and placing a ground on the cathode of BYPASS indicator DS1. The indicator lights, signaling that the 100/500 Watt Antenna Coupler is in bypass mode.

5-17. HOMING CIRCUIT. The positive-going TUNE PULSE at U16-12 is applied to homing flip-flop U17-8, which presets the flip-flop to a low output at U17-10 and a high output at U17-11. The low level

output of U17-10 is called the HOME signal and is coupled through diode CR53 to the base of the HOME SWITCH, Q41, in the servo amplifier circuit to initiate the homing mode.

a. HOMING Signal. The high output at U17-11, called the HOMING signal, is connected to NOR gate U17-6 to reset the timing fault circuit any time the 100/500 Watt Antenna Coupler starts homing. The U17-11 output is also connected across diode CR22 to the base of transistor switch Q22, to prevent transmitter keying while the 100/500 Watt Antenna Coupler is homing. The high level U17-11 output is also connected across diode CR24 to NOR gate U18-8 to reset the RF Present flip-flop and put the 100/500 Watt Antenna Coupler in bypass during homing.

b. High Level Fault Signal. When inductor A2L1 and capacitor A2C1 reach the home positions, the negative logic level signals (MIN L and MAX C) are applied, respectively, to pins 1 and 2 of NOR gate U17. When both signals are low, U17-3 goes high and is applied through diode CR20 to reset the homing flip-flop at U17-13 and stop the Homing Mode. If a high level FAULT signal from U15-4 is applied through diode CR21 to U17-13, the homing flip-flop will reset and stop the Homing Mode.

5-18. TUNE POWER REQUEST. When a TUNE PULSE* signal is initiated from the 100 Watt Transceiver or from the power-up pulse generator circuit, a positive-going TUNE PULSE signal at U16-12 is applied to Ready flip-flop U13-1, to preset the flip-flop to a low at U13-3 and a high at U13-4. The low at U13-3 is combined with the high output (meaning NO RF PRESENT) of rf present flip-flop U13-10 in NOR gate U21-8,9,10 to produce a low output at U21-10. The low U21-10 output is combined with the high homing flip-flop output U17-11 in NOR gate U17-6,5,4 to produce a low output at U17-4 that enables the the tune time fault circuit during homing.

a. TUNE PWR REQ Signal. The output of ready flip-flop U13-4 is connected to the base of transistor switch Q20 in the tune power request circuit. This output, called the READY* (NOT READY) signal, is active high, so that during homing, Q20 is biased on, applying +10 Vdc to the anode of TUNE PWR REQ indicator DS5. When DS5 lights, indicating a request for tuning power, a positive voltage is applied to the base of transistor switch Q21. Q21 is biased on, sending a ground signal to the 100 Watt Transceiver through connector J4-16, as the TUNE PWR REQ

signal. At the same time, the high homing flip-flop output at U17-11 disables the 100 Watt Transceiver key by turning on transistor Q22, so that no rf can be applied to the 100/500 Watt Antenna Coupler while it is homing. When the tuning elements reach their HOME positions, the limit switch signals (MIN L and MAX C) reset the homing flip-flop while the ready flip-flop remains preset. Resetting the homing flip-flop removes the KEY DISABLE signal to the 100 Watt Transceiver by applying a low to the base of transistor switch Q22. Since the ready flip-flop preset condition is still sending a TUNE PWR REQ signal to the 100 Watt Transceiver and the KEY is no longer inhibited, the 100 Watt Transceiver applies the low power rf tuning signal to the input of the 100/500 Watt Antenna Coupler. When a sufficient rf level is detected in the 100/500 Watt Antenna Coupler, tuning begins.

b. Ready Flip-Flop. With the ready flip-flop reset, the rf signal generation is started when the 100/500 Watt Antenna Coupler has homed and U17-11 goes low. This low logic level is blocked by diode CR22, allowing U18-8 to be at a low level through R38. If U18-9 is low, indicating there is a transmitter KEY and that RF is present, a high level LATCH signal is produced at U18-10. This high level LATCH signal is used to enable the three NOR gates of U22. When the VSWR is less than 2:1, a high is applied to U22-5. The combination of these two signals produces a low at U22-4 and at one input of NOR gate U18. When the VSWR is less than 1.2:1, a low is applied to U22-12 through resistor R42. This forces NAND gate output U22-11 to be high. This output is applied to NOR gate input U23-9, causing U23-10 to go low. This low is applied to both U18-6 and U23-12. The low at U18-6 in combination with the low at U18-5 produces a high at U18-4. The output at U18-4 is applied to the input of a time delay circuit that consists of R43, R44, C18, and CR32. After a time delay of approximately 1.5 seconds, the high level signal is applied to the U13-6 reset input of the ready flip-flop. This reset causes a high to appear at U13-3 and a low at U13-4. The low at U13-4 cancels the TUNE POWER REQUEST to the 100 Watt Transceiver, signaling that the 100/500 Watt Antenna Coupler is READY for normal transmission. The low at NOR gate input U23-12 causes a high output at U23-11. This high is applied to U18-1 through diode CR77. A high at U18-1 forces the output U18-3 to be low, removing the SERVO ENABLE signal and disabling the servos. The high output at U13-3, combined with outputs from the rf present flip-flop and the homing flip-flop, disables the tune time fault circuit.

c. VSWR Fault and Servo Surveillance. The low at U13-4 is also applied to U21-2 to enable the VSWR Greater than 2:1 Fault circuit. Once enabled, U23-3 will go high if U21-1 ever goes low. A high at U21-3 causes a high at U19-12 and a low at U19-11. This low is applied to the set input of the FAULT flip-flop through delay circuit R46 and C19. U21-1 goes low through R189 whenever "VSWR less than 2:1" goes low, indicating the VSWR is greater than 2:1. At the same time, U22-5 goes low, forcing U22-4 high and U18-4 low. Since the VSWR is also greater than 1.2:1, U22-12 is also high and with U22-13 high, U23-11 goes low. With a low at both U23-9 and U23-8, U23-10 is high. A high at U23-12 causes U23-11 to be low, thus reverse biasing both CR77 and CR89. With both diodes reverse biased, U18-1 is low and U18-3 is high, enabling the servos to correct for the high VSWR. The correction must be accomplished before the delay of R46 and C19 to the input of the Fault flip-flop times out, or a VSWR fault will occur.

5-19. RF PRESENT FLIP-FLOP. The rf present flip-flop is used as a control device in the 100/500 Watt Antenna Coupler. When the Tune Mode is initiated, the positive going TUNE 1 PULSE at U16-2 is applied to the rf present flip-flop at U13-13 to preset the flip-flop. This causes U13-10 to go high and U13-11 to go low, indicating that no rf signal is present. During this preset condition, the U13-10 output is used to initiate two actions. (1) The U13-10 output is applied to NOR gate U21-8 to help enable the tune time fault circuit. The U13-10 output is applied to U21-8 and the ready flip-flop output U13-3 is applied to U21-9. When U21-8 is high, indicating there is no rf present, and U21-9 is low, indicating that the 100/500 Watt Antenna Coupler is not ready, a low is generated at U21-10 and applied to U17-5. If input U17-6 is high, indicating the 100/500 Watt Antenna Coupler is homing, a low is generated at U17-4 to enable the tune time fault circuit during the Homing Mode. (2) The U13-10 high output is also applied through diode CR11 to the input of the bypass relay latch circuit to place the 100/500 Watt Antenna Coupler in BYPASS during homing.

The rf present flip-flop becomes set when two conditions occur: (1) when the KEY signal at J4-5 changes from an open to a ground, indicating the Transmitter is keyed, and (2) when the output of the RF ON threshold detector U10-7 goes high, indicating the presence of forward power in the 100/500 Watt Antenna Coupler rf signal path. The KEY signal is inverted by U11-5,4 and applied to

T.O. 31R2-2URC-111

NAND gate U22-2. The RF ON signal is derived from the output of the RF ON threshold detector and is applied through diode CR51 to the U22-1 input. If both U22-1 and 2 are high, a low is generated at U22-3. This signal is applied to U16-14/15 to become the relay latch CLOCK signal to U9-5. The signal is also applied to NOR gate U18-9, which acts like an AND gate whose other input, U18-8, is controlled by the U17-11 output of the homing flip-flop and the U15-4 output of the fault flip-flop. All of these signals must be low in order to remove the BYPASS condition. These low signals produce a high logic level at U18-10, which is applied across a time delay network consisting of R39, R40, C17, and CR25, to the U13-4 input of the rf present flip-flop. When U13 resets, the output at U13-10 goes low. This low is applied through R187 to U11-9. U11-10 goes high, biasing Q52 on, which applies a key hold signal to the transceiver. This is reset through CR80 when the Ready flip-flop is set.

5-20. LONG WIRE ADAPTER RELAY CONTROL. Part of U9 is used as the relay latch to control the long wire adapter relay (called the "C" relay) in the A2 Lower Shelf Assembly. The latch input, U9-7, goes high whenever the Q output of the Tune 1/Tune 2 flip-flop at U19-3 goes high, indicating that the 100/500 Watt Antenna Coupler is in the Tune 2 Mode. The "C" relay latch is clocked by the same signal that clocks the bypass relay latch. The CLOCK signal from inverter U16-15 is applied to U9-5. When the input at U9-7 is high, a positive voltage is produced at the output, U9-10.

NOTE

There are two jumpers, J9 and J10, at the output of U9. For normal operation, the jumper bar should be placed across J9. Placing the jumper bar across J10 inserts the long wire adapter (capacitor) for the first tune cycle and removes the capacitor for the second tune cycle.

The output of the "C" relay latch is applied to the base of transistor switch Q17, causing Q17 to conduct and applying a positive voltage to the base of relay driver Q18 and Q19. Q18 conducts, applying a positive voltage to the base of Q19. When Q19 conducts, a ground, called the "C" RELAY signal, is applied to two places in the 100/500 Watt Antenna Coupler: (1) through connector J5-26 to the ground side of long wire adapter relay A2K1 to energize the relay; and (2)

to the cathode of "C" SELECTED indicator DS4 causing the LED to light. This indicates that the 100/500 Watt Antenna Coupler is in the Tune 2 Mode and the long wire adapter is selected. Included as part of the "C" relay latch circuitry is the relay change request detector that consists of exclusive NOR gate U12 used as a NAND. The input of the bypass relay latch at U9-14 is tied to one input of exclusive NOR gate U12-8, while the output of the bypass relay latch at U9-1 is tied to the other input, U12-9. The input of the "C" relay latch, U9-7, is likewise tied to one of the inputs of an exclusive NOR, U12-12, while the output of the "C" relay latch U9-10 is tied to the other NOR input, U12-13. If a change occurs at the input or the output of either latch, a high will be produced at pin 10 or 11 of U12. Pins 10 and 11 of U12 are gated by diodes CR38 and CR39 to produce a KEY DISABLE signal that is applied to the base of key disable switch Q22.

5-21. SERVO DISABLE. The +10 Vdc SERVO DISABLE signal input to amplifiers U2-6, U3-6, U4-6, and U5-6 is generated when the VSWR greater than 1.2:1 signal at U8-7 goes low, indicating that the VSWR is not greater than 1.2:1. This signal is applied to NOR gate U22-12. If U22-13 is low, a high will appear at U22-11. The high level signal output at U22-11 is applied to NOR gate U18-1, while the BYPASS output of U11-2 is applied to U18-2. If either one of these signals goes high, a low level SERVO DISABLE signal will appear at U18-3. The SERVO DISABLE signal line is applied to inverter U11-14/15, along with both the HOME and the FORCE signal inputs from switch S1. When the +10 Vdc (HOME or FORCE) signal is applied to the inverter, a low signal level is applied to the base of transistor Q27, holding it off. This condition enables the servo amplifiers. When a low signal level is applied to the input of the inverter, a high is applied to the base of Q27, biasing it on. This applies +10 Vdc to the servo amplifier disable inputs. When the servo amplifiers are disabled, indicator DS7, SERVO DISABLE, is turned on.

5-22. KEY DISABLE CIRCUITS. A high level KEY DISABLE signal from either the relay change request detector, U12, or from the output of the homing flip-flop at U17-11 via steering diode CR22, causes transistor switch Q22 to conduct. When Q22 conducts, a +10 Vdc KEY DISABLE signal is applied through steering diode CR79 to the pin 9 input of inverter U11 to disable keyhold switch Q52. The +10 Vdc KEY DISABLE signal is also applied across the time delay network, C86 and R64, to the anode of KEY DISABLE indicator DS6. Indicator DS6 lights and

transistor switch Q23 is biased on, applying a ground signal through connector J4-9 to the 100 Watt Transceiver as the KEY DISABLE signal. Thus, if there is any change in the state of the relay latches, the Transmitter is forced to unkey.

5-23. FAULT FLIP-FLOP. When the Tune Mode starts, the negative-going TUNE PULSE, at U16-10, is applied to tune time fault flip-flop U15-1 to reset the flip-flop to a low at U15-4 and a high at U15-3, which is the no-fault condition. Thereafter, the presence of two signals is required to set the flip-flop to the fault condition: (1) a signal that indicates that 20 seconds have elapsed since reset and (2) the VSWR >2:1 signal. The tune time fault reset is generated by applying the positive-going TUNE PULSE at U16-12 through diode CR18 to the base of transistor switch Q53. This positive-going pulse or a positive-going pulse from NOR gate U17-4 indicating that homing has been completed and rf is present, is applied, through diode CR19, to turn on transistor switch Q53. When Q53 conducts, timing fault capacitor C13 discharges to ground and resets the timing fault circuit timer to zero. If, during tuning, the timing fault capacitor is allowed to charge, indicating that 20 seconds has elapsed since reset, a high logic level will appear at U20-1. The signal from the timer appears as a low at U20-3, which is inverted to a high logic level by U20-12/11 and applied to U19-13. A high at U19-13 causes a low at U19-11 and U15-6 through time delay network R46 and C19, setting the Fault flip-flop.

When the Fault flip-flop is set, U15-3 goes low and U15-4 goes high, indicating a fault condition. The low level FAULT signal from U15-3 is applied to U19-8, one input of a 2-input NOR gate used as a NAND gate. The other input, U19-9, is connected to the U19-4 output of the Tune 1/Tune 2 flip-flop. U15-4 is connected to the TUNE 1/TUNE 2 flip-flop through diode CR 35, so that when a fault occurs, the flip-flop is set in the TUNE 2 condition. Whenever U19-9 is low, indicating the Tune 2 Mode, at the same time that U19-8 is low, indicating a fault, the output at U19-10 will go high. This high output at U19-10 is used to initiate two actions in the 100/500 Watt Antenna Coupler: (1) it is applied to the Bypass circuit across diode CR10 as the BYPASS signal to place the 100/500 Watt Antenna Coupler in BYPASS, and (2) it is applied to the base of transistor switch Q15 to bias on the transistor, thereby applying +10 Vdc to the anode of TIME FAULT indicator DS3. When DS3 lights, a positive voltage is applied to the base of transistor switch Q16. This turns on Q16, applying a

ground signal through connector J4-4 to the 100 Watt Transceiver as the TUNE TIME FAULT signal.

5-24. FAN CONTROL AND THERMAL FAULTS. The fan is turned on if the 100/500 Watt Antenna Coupler is connected to a high power PA (500 Watt LPA) and the Transmitter is keyed. This is done in order to cool the 100/500 Watt Antenna Coupler during high power operation. An LPA ID* signal from the 100 Watt Transceiver indicates that a high power PA is connected between the 100 Watt Transceiver and the 100/500 Watt Antenna Coupler. This signal is applied through J4-8 to pin 12 of NOR gate U21. A KEY signal from the 100 Watt Transceiver, indicating the 100 Watt Transceiver is keyed, is applied through J4-5 to pin 13 of the same U21 NOR gate. The NOR gate acts like an AND gate to the low logic level inputs. Both input signals must be low in order to produce the high output signal used to turn on transistor switch Q5. When Q5 turns on, +10 Vdc is applied through R11 and DS1 to the base of Darlington transistor Q7, whose output (a ground) is the FAN signal at J5-32. DS1 is the FAN RUNNING indicator.

If the thermostat switch A2A2S1 closes, indicating that A2L1 has reached a temperature of 95° C, a low will be applied to pin 8 of NAND gate U20. This low logic level produces a high-going signal at U20-10, which, in turn, turns on transistor switch Q24. When Q24 conducts, a ground is applied to J4-12 as the THERMAL FAULT signal to the 100 Watt Transceiver.

5-25. SERVO SYSTEM. The servo system consists of a pair of complementary TO3 Darlington amplifiers. The servo amplifiers are designed so that if either servo motor is not being driven in one direction or the other, a short will appear across the motor winding, applying automatic braking to the servo motor. The ERROR signal is applied to one input of the amplifier and a ramp voltage waveform is applied to the other input. If the ERROR signal is greater than the RAMP voltage, the motor runs full speed in the direction required to cancel the ERROR signal. However, as the ERROR signal becomes smaller, and finally becomes less than the peak RAMP voltage, the motor begins to slow down and to brake. Once the ERROR signal is less than the bottom of the RAMP, the motor is braked all of the time. Combined with the automatic braking feature is the servo disable circuit, which is controlled by the VSWR detector. The disable circuit shuts off the servos completely when the VSWR reaches 1.2:1, the tuned condition. There is no overshoot in this servo system because the

T.O. 31R2-2URC-111

servos are alternately braked and driven, in increasing proportion, as the error signal decreases. As they reach the tuned condition, they are braked and shut off completely.

a. Homing. When a TUNE PULSE is applied to the U17-8 input of the homing flip-flop, a low level HOME signal at U17-10 is applied through diode CR53 to the base of Home Switch, Q41, in the servo amplifier circuit. The negative-going pulse on the base of Q41 biases the transistor on, applying +10 Vdc to both servo amplifiers through diodes CR54 and CR55 and resistors R144 and R145. This forces the servos to drive to their HOME positions. At the same time, a high level pulse, from U17-11, is applied through diode CR22 to the Key Disable circuit to disable the 100 Watt Transceiver key while the 100/500 Watt Antenna Coupler is homing.

b. Servo Test Posts, J11 and J12. The servo amplifiers can be manually driven to either the HOME position or the FORCE position by the SERVO TEST POSTS, J11 and J12, located on the A1 logic PWB Assembly. When a set of posts is temporarily connected (as by shorting them together with a screwdriver, for example), the motor moves in the HOME (J11) or FORCE (J12) direction. Removing the temporary connection at J11 or J12 removes the applied +10 Vdc drive signal and stops the motor.

c. LOAD ERROR Signal. The operation of the L1 variable inductor servo amplifier system begins with application of the LOAD ERROR signal. The LOAD ERROR signal from load error detector U10-1 is applied across resistors R107, R144, and R136 to operational amplifier U2-5 and 1:1 inverter U14-5/6/7. The inverted output of U14-7 is applied to operational amplifier U3-5 so that the input at U3-5 is exactly opposite to the input at U2-5. As an example, if a +1 volt LOAD ERROR signal is applied to U2-5, a -1 volt LOAD ERROR signal is applied to U3-5. The RAMP signal from sawtooth generator U1-7 is applied to pin 6 of both U2 and U3 so that the input LOAD ERROR signals are compared to the RAMP signal. The RAMP swings from 0 volts to +3 volts. The output at U2-7 is a square wave from +10 to -10 signal volts, with a duty cycle of 0 to 100%. If the output at U2-7 swings from +10 to -10 volts, then the output of U2-1 will be exactly opposite, i.e., will swing from -10 to +10 volts. If U2-7 is high, then Q29 is turned on. When Q29 is turned on, Q33 turns on. If Q33 is turned on, then Q37 turns off, because of the signal path through diode CR67 to the base of Q37. If a high is applied to the base of Q29, then a low is applied to the base of

Q37. Diode CR67 ensures that both transistors do not turn on at the same time. When Q33 is on, a high level drive voltage is applied through connectors J5-21, -22, and -23 to the drive motor A2A1B2-1. Any time that Q33 is turned on, Q37 is turned off. The inverse is also true: any time that Q33 is turned off, Q37 is turned on, applying a ground through connectors J5-21, -22, and -23 to A2A1B2-1 of the drive motor. Current limiting is provided for this servo amplifier by transistor Q48 and resistor R176. If the current drawn by the drive motor exceeds 2.5 amperes, a 0.6 voltage drop across the base-to-emitter junction of Q48 turns on Q48. With Q48 turned on, 13.6V is applied to the base of Q33, turning it off. With the output at U2-7 a high, U3-7 is a low and U3-1 is a high, since U3-1/2/3 is a 1:1 inverter. Also, since the output of U3-1 is high, Q38 will be turned on, applying a constant ground signal through connectors J5-15,-16 -17 to A2A1B2-2 of the drive motor. At the same time, the output at U3-7 turns off Q34. Control of the variable capacitor servo amplifier system works the same way as the variable inductor servo amplifier system.

5-26. POWER SUPPLIES.

a. +10 Vdc Power Supply. The +13.6 Vdc input from the 100 Watt Transceiver is applied to the A1 Logic PWB Assembly via connector J4 pins 10, 11, 13, and 14 for current carrying capability. A current limiting and overvoltage protection circuit provides a +10 Vdc output for distribution to logic circuits. The pass element of this circuit is transistor Q8. Transistor Q9 establishes the gain of Q8. Voltage regulator VR1 clamps the voltage at the base of Q9 to +12 Vdc. Transistor Q8 responds to an overvoltage on the input line and to excessive current drain. An overvoltage condition is detected by an increased voltage drop across R16. This voltage drop decreases the base current of Q9, causing it to conduct less. Since Q9 controls the output of Q8, transistor Q8 conducts less, offering more resistance to the input voltage. More of the input voltage is then dropped across Q8, maintaining its output at +10 Vdc. An overcurrent condition is detected by R15 and Q10. If current flowing through R15 and R180 becomes sufficient to cause a 0.6 volt drop across Q10, Q10 turns on, diverting base current from Q9 and Q8 and reducing the current supplied to the load.

b. -10 Vdc Power Supply. The DC/DC converter circuit on the A1 Logic PWB Assembly consists of transistors Q1-Q2, diodes CR1-CR3, T1, and their associated resistors and capacitors. Its purpose is to

change +13.6 Vdc to -10 Vdc. The output of the Q1/Q2 flip-flop is coupled to the secondary of T1, where it is rectified by CR2 and CR3. The resulting

negative-going half cycles are then filtered by C5, C6, C8, and L3 to provide the -10 Vdc distribution voltage for the A1 Logic PWB Assembly.

CHAPTER 6

MAINTENANCE

WARNING

Dangerous voltages exist in this radio equipment. Before removing any covers, disconnect the primary power and the RF source.

Section I. INTRODUCTION

6-1. CHAPTER ORGANIZATION. This chapter is divided into five sections. Section I tells how the chapter is organized, describes the on-equipment maintenance philosophy, and introduces you to the concept of BIT (Built-In Test). Section II is a detailed presentation of how to use BIT to troubleshoot and repair the 100/500 Watt Antenna Coupler. Section III consists of removal and replacement procedures for the faulty modules identified by BIT. Section IV is dedicated to Periodic Maintenance Procedures. Section V contains alignment procedures for the replaceable modules.

6-2. ON-EQUIPMENT MAINTENANCE PHILOSOPHY. The 100/500 Watt Antenna Coupler is designed so that you can make most repairs without removing the equipment from its location. The procedures in this chapter should enable you to identify and correct most equipment malfunctions within 15 minutes.

NOTE

Field and Organizational Maintenance of the modules and circuit card assemblies is limited only to the removal, replacement, and alignments given in chapter 6.

Tool List

Screwdrivers:
 3/16-inch flat blade (4 inches long)
 No. 1 Phillips
 No. 2 Phillips
 Wrenches:
 6-inch adjustable

6-3. BIT (BUILT-IN TEST). The key to servicing the 100/500 Watt Antenna Coupler is a feature called BIT. BIT, which is an acronym for Built-In Test, consists of several elements. These elements are:

- o A series of eleven LEDs on the Logic PWB Assembly which monitor key logic and analog levels during the tuning process
- o Test points (J11, J12) on the Logic PWB Assembly which allow manual slewing of the two servo motors in order to check servo drive, the motors themselves, and the limit switches
- o Automatic fault monitoring, which generates two fault codes (indicating a tuning fault or a temperature fault) on the 100 Watt Transceiver's display panel
- o A power meter on the 100 Watt Transceiver which indicates forward power, reflected power, and VSWR

When used in conjunction with this manual, these elements allow rapid and accurate fault diagnosis.

Section II. PERFORMANCE TESTING AND TROUBLE ANALYSIS USING BIT

6-4. LED INDICATORS. Table 6-1 below lists the eleven LEDs on the Logic PWB Assembly inside the 100/500 Watt Antenna Coupler and describes

what each one indicates when it is on. You will use this table in conjunction with the fault codes in Table 6-2 to diagnose and repair antenna coupler faults.

Table 6-1. Logic PWB Assembly LEDs and Their Functions

LED	Function
DS1	Indicates that the fan is running.
DS2	Indicates when the coupler is bypassed so that the transceiver is connected directly to the antenna.
DS3	Indicates a time fault. A time fault is declared when the coupler is unable to tune after a period of twice the normal tune time (20 seconds approximately).
DS4	Indicates "C" selected. If the normal coupler network fails to tune the antenna, the coupler tries again, but with a series capacitor connected between the antenna and the variable tuning elements.
DS5	Indicates tune power request. Tune power is requested by the coupler whenever a tune cycle is required and the elements are at their home positions.
DS6	Indicates key disable. A key disable occurs whenever the tuning process requires that rf be removed. When the coil tuning elements go to "home" or when the bypass relay changes state are examples of when the key is disabled.
DS7	Indicates servos disabled. The servos are disabled after a tuning process has been completed.
DS8	Indicates the variable coil is being driven toward minimum L.
DS9	Indicates that the variable coil is being driven toward maximum L.
DS10	Indicates that the variable capacitor is being driven toward minimum C.
DS11	Indicates that the variable capacitor is being driven toward maximum C.

6-5. TROUBLESHOOTING WITH BIT. The first stage in the troubleshooting process is becoming aware that a fault condition exists. This usually happens as the result of an observation (for example, you notice that the FAULT light on the 100 Watt Transceiver is on) or as the result of a deterioration in

the equipment's performance (for example, the person you're communicating with informs you that your signal is very weak). In any case, it's always a good idea to make a note whenever you notice anything unusual. This will come in handy if you have to do any troubleshooting.

a. Installing a Dummy Load. When there are problems with an antenna system, it is sometimes very difficult to determine whether the problem is in the antenna or in the antenna coupler. Therefore, if you suspect that there is a problem with your antenna system, disconnect the antenna coupler from the antenna and connect it to a 50-ohm dummy load which is capable of dissipating at least 500 watts. This not only isolates the antenna from the coupler, thereby eliminating the variabilities of the antenna; but it also prevents the radiation of rf during the troubleshooting process.

b. Using the Fault Code Troubleshooting Chart. Table 6-2 is a troubleshooting chart designed to help you isolate failures in the 100/500 Watt Antenna Coupler to one of two replaceable modules. These two modules are the Logic PWB Assembly, which contains the digital and analog circuits used to operate the tuning elements, and the Lower Shelf

Assembly, which contains the tuning elements and the motors that drive them. The table is based upon two fault codes that are generated by the monitoring circuits in the antenna coupler and then sent to the 100 Watt Transceiver for display. Fault code 3-01, which is a tune-time fault, is declared if the antenna coupler has not achieved a VSWR of less than 1.2:1 within 20 seconds after a tuning cycle has been initiated. Fault code 3-02, which is a thermal fault, is declared if the internal temperature of the antenna coupler exceeds 95⁰ C. The fault codes by themselves are not always sufficient to isolate the problem; you will sometimes be required to do some additional checking. This is the reason for the special procedure for fault code 3-01. Table 6-2 tells you what to do to fix the problem, which consists of replacing either the Logic PWB Assembly or the Lower Shelf Assembly. Instructions for removing and replacing these two modules are contained in Section III of this chapter, "Removal/Replacement Procedures."

Table 6-2. 100/500 Watt Antenna Coupler Troubleshooting Chart

Code	Explanation	Procedure
3-01	TUNE-TIME FAULT	See the procedure below.
3-02	OVERTEMPERATURE FAULT	Replace the Lower Shelf Assembly.

Fault Code 3-01 Procedure

1. Replace the antenna with a 50-ohm dummy load of sufficient wattage for your system and attempt to retune. If this eliminates the problem check and repair your antenna system. If the fault persists, continue with this procedure.
2. Remove the cover from the antenna coupler. Loosen the five captive screws

and raise the top shelf to its upright position, so that the motion of the tuning elements may be observed. Change the frequency of the transceiver by 1 MHz and key it. The tuning elements should go to "home," if not already there. LEDs DS8 through DS11 should indicate the direction of drive to the servo motors. Refer to the symptoms below to isolate the the problem.

SYMPTOM	PROCEDURE
a. Both servo motors were inactive when the LEDs indicated that they should be moving.	Replace the Logic PWB Assembly.
b. Either tuning element is at mid range but is not moving. (Short J11 or J12 to move the elements off the end stops if necessary.)	Replace the Lower Shelf Assembly.
c. Either tuning element runs in only one direction, but the LEDs indicate commands to go in both directions.	Replace the Lower Shelf Assembly.
d. The LEDs do not give the proper indication when J11 or J12 (on the Logic PWB Assembly) is shorted.	Replace the Logic PWB Assembly.
e. The coupler does not tune a 50-ohm load below 10 MHz, but tunes above 15 MHz. (1). DS4 does not light in either case. (2). DS4 lights below 10 MHz.	Replace the Logic PWB Assembly. Replace the Lower Shelf Assembly.
f. The coupler achieves a low VSWR (check VSWR with the meter on the 100 Watt Transceiver), but DS1 does not light and the servo motors stay enabled.	Replace the Logic PWB Assembly.
g. The coupler achieves a low VSWR, but the servo motors oscillate rapidly about the tune point.	Replace the Logic PWB Assembly.
h. Faulty or erratic tuning occurs with the servo motors and switches working properly.	Replace the Lower Shelf Assembly. If the problem persists, replace the Logic PWB Assembly.

Section: III. REMOVAL/REPLACEMENT PROCEDURES**CAUTION**

Use care when disconnecting ribbon cables, coax cables, etc.

NOTE

Refer to drawing FO-3 while doing the following procedures. This drawing has an apron which allows you to look at it while reading the procedures. The numbers in parentheses in the procedural steps correspond to the numbered items on the drawing.

6-6. LOGIC PWB ASSEMBLY.**a. Removal.**

- (1) Disconnect the RF input cable and the power/control cable at the back of the 100/500 Watt Antenna Coupler.
- (2) Twist the handles on the four latches (1) counterclockwise, and remove the top cover (2).
- (3) Disconnect the three cables from the Logic PWB Assembly (5).
- (4) Loosen the five slotted, spring-loaded captive screws (3), and raise the top shelf to its upright position.

NOTE

Make a note of the positions of the coax cables before disconnecting them. J1 is the input connector and J2 is the output connector.

- (5) Disconnect the two coax cables and the white high-voltage wire from the RF PWB.
- (6) Remove the four Phillips screws (7) holding the RF PWB Assembly to the top shelf.
- (7) Lower the top shelf to its horizontal position.

- (8) Loosen the eight captive Phillips screws holding the Logic PWB Assembly to the top shelf (4).
- (9) Remove the Logic PWB Assembly (which includes the attached RF PWB Assembly) from the antenna coupler.

b. Replacement.

Reverse the order of the above steps.

6-7. LOWER SHELF ASSEMBLY.**a. Removal.**

- (1) Disconnect the RF input cable and the power/control cable at the back of the 500 Watt Antenna Coupler.
- (2) Twist the handles on the four latches (1) counterclockwise, and remove the top cover (2).
- (3) Disconnect the two Lower Shelf Assembly cables that plug into the in-line connectors on the Logic PWB Assembly (5).
- (4) Remove the cable clamp holding the Lower Shelf Assembly cables to the top side of the top shelf (4).
- (5) Loosen the five slotted, spring-loaded captive screws (3), and raise the top shelf to its upright position.
- (6) Disconnect the coax cable from connector J2 on the RF PWB Assembly (6).
- (7) Disconnect the white high-voltage wire from the RF PWB Assembly.
- (8) Loosen the Phillips screw (8), and disconnect the white wire from the plastic standoff (9).
- (9) Loosen the six slotted, spring-loaded captive screws (10) holding the Lower Shelf Assembly (11) to the chassis.
- (10) Carefully lift out the Lower Shelf Assembly from the chassis.

Section IV. PERIODIC MAINTENANCE PROCEDURES

b. Replacement.

NOTE

Before installing the 10094-0120 Assembly into the case, loosen both set-screws on the tune capacitor drive coupling (cap end). After tightening all the mounting screws, retighten the set screws.

Reverse the order of the above steps.

6-8. PERIODIC MAINTENANCE ACTIONS.

The 100/500 Watt Antenna Coupler requires only a limited amount of periodic maintenance. The following actions are recommended at the intervals listed. During any of the specific procedures listed, take note of any unusual equipment conditions which may indicate degrading or degraded performance, and make the necessary corrections.

a. Cleaning and Lubrication. Every 168 days of operation or 500 tune cycles, whichever comes first, do the following:

NOTE

Observe the exact position of the tune and follower rollers before proceeding.

- (1) Clean the coil turns, coil shafts, and the electrical contacts on the coil shafts with isopropyl alcohol.
- (2) Apply a light coating of Dow Corning DC 44 (FSCM 71984) silicon lubricant to the coil turns using a soft, lint free cloth. The lubricant should be invisible to the naked eye but sufficient to make the turns feel slippery.

- (3) Apply a heavier, slightly visible coating to each of the electrical contact shafts and to the spring contact shafts. Some lubricant buildup, after running the coil, is acceptable.
- (4) Apply one drop of Anderol 401D (FSCM 99559) instrument oil (or equivalent silicone oil) to each of the oilite bushings in the coil end plates. It is not necessary to apply lubricant to the nylon gears.



Assure the tuning and follower rollers are in their original positions. If in doubt, perform the alignment procedure in paragraph 6-10b (1), (2).

b. Visual Inspection. Every 336 days, inspect the interior of the unit and check for any signs of arcing or corrosion. Check the arc gap located near the E1 terminal output in particular.

Section V. ALIGNMENT PROCEDURES

6-9 INTRODUCTION. This section contains instructions for checking and adjusting the replaceable subassemblies in the 100/500 Watt Antenna Coupler. This section also contains

illustrations to help you identify the components that can be adjusted. To do the procedures described in this section, you need the test equipment listed in Table 6-3.

Table 6-3. Test Equipment*

Generic Name	Military Designation	Manufacturer Model No.	Federal Stock No.	Required Range
Digital Multimeter		Fluke, Model 8012A		10 mV to 13.6 Vdc; 0 to infinity ohms
Dummy Load		Bird, Model 8833		500 W (pk), 250 W (avg), 50 ohms
Electronic Voltmeter w/ AC Probe & T-connector		Hewlett Packard Model 410C Model 11036A Model 11042A		10 to 100 V rms; 1.6 to 30 MHz (peak reading)
100 Watt Transceiver	RT-1445/URC	RF Communications Model RF-350	5820-01-162 3406	
Feeler gauge				2.3-2.5 mm

*NOTE: Equivalent Items Authorized

6-10. ALIGNMENT PROCEDURES.

a. Logic PWB Assembly A1. (see figure 6-1).

**C31, Reflected Power Adjustment
R71, Phase Error Adjustment
C36, Load Error Adjustment**



High RF voltages may be present in the coupler during this alignment.

NOTE

These adjustments are interrelated and should always be done together.

- (1) Connect a dummy load to the RF output connector of the antenna coupler.
- (2) Turn on the transceiver. Set the frequency to 29.999 MHz in CW mode.
- (3) Tune the antenna coupler either with a momentary closure of the CW key or by pressing [2ND] [TX KEY] [2ND] [TX KEY]. The coupler will either (a) attempt to tune twice and then fault, going into the BYPASS mode, or (b) tune properly.
- (4) Remove the top cover of the coupler.
- (5) Loosen the five captive screws and raise the top shelf to its upright position.
- (6) Using a jumper, short the temperature switch (S1) output to ground (this is an insulated standoff on the outboard side of the motor mounting plate (see figure 6-1) This will place the coupler into BYPASS mode.

- (7) Disconnect the RF output coax connector P1 from J2 on the RF PWB Assembly. See figure 6-1.
- (8) Connect a 50 ohm dummy load to J2 on the RF PWB Assembly.
- (9) Connect an HP410C voltmeter between TP2 and ground on the Logic PWB Assembly (see figure 6-2). Use 5 Vdc scale.
- (10) Key the transceiver with the CW key.
- (11) Adjust C31 on the Logic PWB Assembly for a voltage null (a dip in the meter reading).

NOTE

Since the capacitor can be rotated a full 360 degrees (that is, from minimum capacitance to maximum capacitance and back to minimum capacitance), be careful not to mistake the capacitor null for a voltage null. A capacitor null is when the voltage null occurs at either maximum or minimum capacitance. (Figure 6-3 shows how the capacitor looks at either minimum or maximum capacitance).

- (12) Connect the HP410C voltmeter between TP5 and ground. Use 1.5 Vdc scale.
- (13) Adjust C36 for 0 Vdc \pm 200 mV.
- (14) Connect the voltmeter between TP4 and ground. Use 5 Vdc scale.
- (15) Adjust R71 for +0.0 Vdc \pm 100 mV.
- (16) Unkey the transceiver, disconnect the load from J2, connect the RF output coax connector P1, disconnect the jumper from S1, lower the top shelf, and replace the top cover, making sure that all hardware is secure.
- (17) Turn system OFF to reset from coupler BYPASS Mode (enabled in step 6-10 a (6)).

b. Lower Shelf Assembly, A2

NOTE

Refer to paragraph 6-7 for instructions on the removal of the Lower Shelf Assembly. The following procedures are done with the Lower Shelf Assembly out of the antenna coupler.

(1) Variable Coil L1 Limit Switch Adjustment

CAUTION

In the next step, do not rotate the coil beyond the limit switch activation point (audible click is heard), or the switch activation lever may be bent.

- (a) Using finger contact on the non-metallic coil surface, rotate the variable coil L1 clockwise (as viewed from the driven end of the coil) toward minimum inductance until the MIN L limit switch (figure 6-1) actuates (an audible click should be heard). The mechanical end stop of the coil should be between 5/8 and 3/4 of a turn clockwise from this point.
- (b) If the mechanical end stop is more than 3/4 of a turn or less than 5/8 of a turn clockwise from this point, do steps (c) - (f).
- (c) Adjust the coil so that it is 5/8 of a turn from the mechanical end stop.
- (d) Loosen the screw securing the coil limit switch assembly.
- (e) Move the switch assembly slightly in the appropriate direction and retighten the screw.

NOTE

If the initial setting was less than 5/8 of a turn from the mechanical end stop, rotate the limit switch assembly upwards. If the initial setting was greater than 3/4 of a turn, rotate the switch assembly downwards.

- (f) Recheck where the limit switch actuates and repeat this procedure if necessary.

(2) Variable Coil Roller Alignment

- (a) There should be 18 turns of the coil between the TUNE roller and the FOLLOWER roller. Refer to figure 6-4 for the correct alignment. If the alignment is not correct, do steps (b) - (d).
- (b) Adjust the coil so that the tune roller is one turn away from the mechanical end stop at MIN L.
- (c) Adjust the follower roller by carefully lifting the roller off the coil and sliding it to the 20th turn from the mechanical end stop.

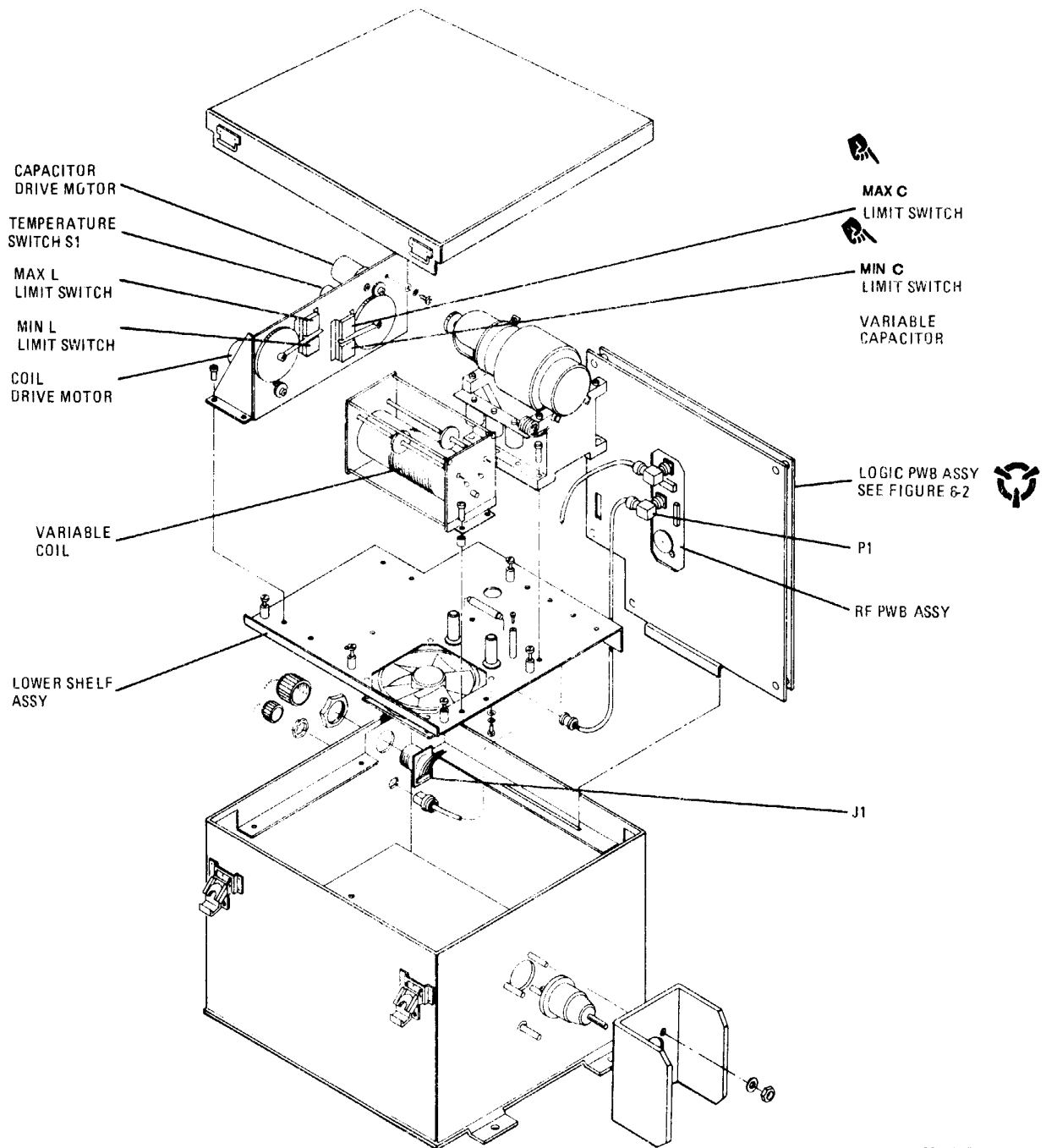

351-017

Figure 6-1. 100/500 Watt Antenna Coupler

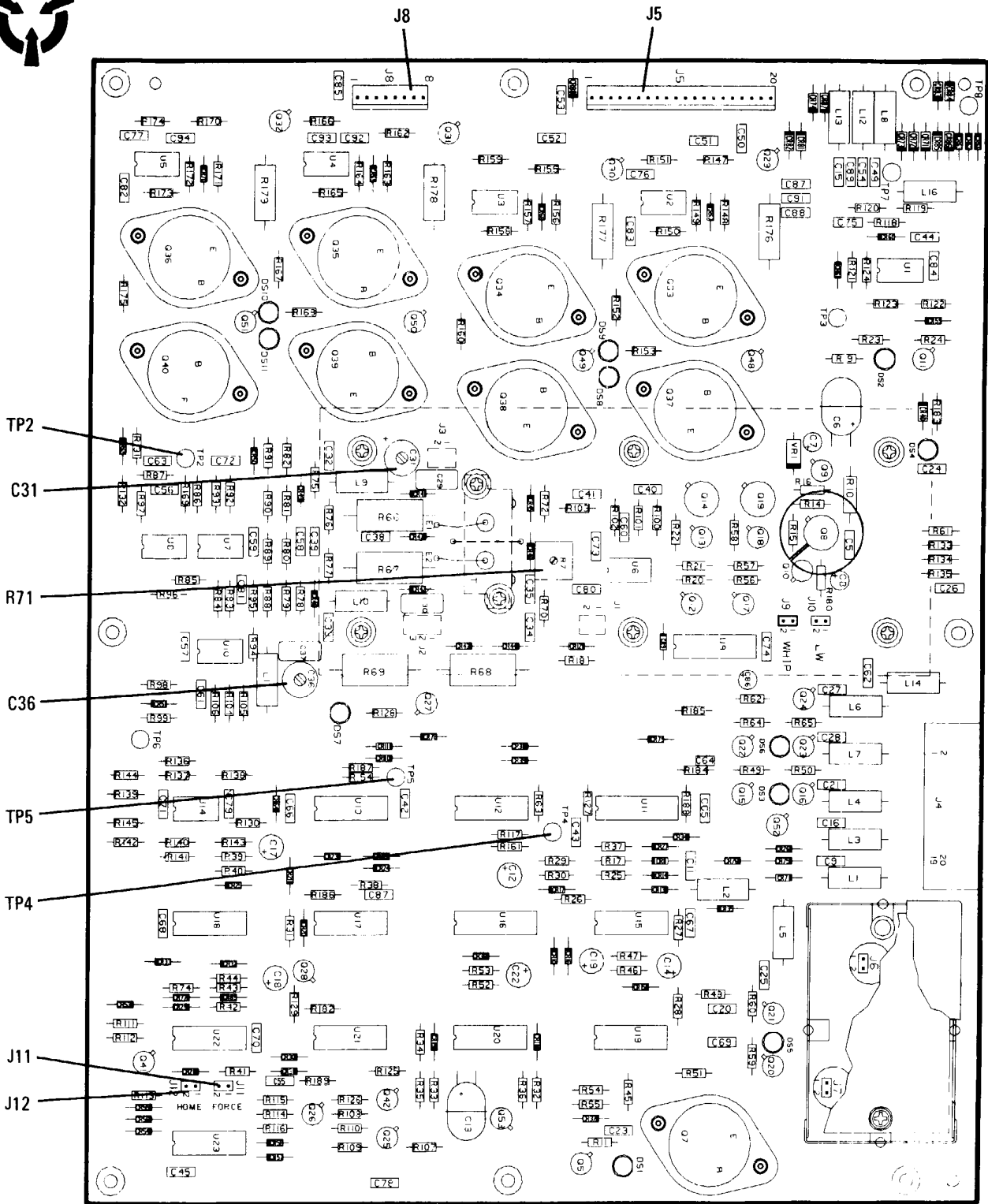

351-016A

Figure 6-2. Logic PWB Assy Component Layout

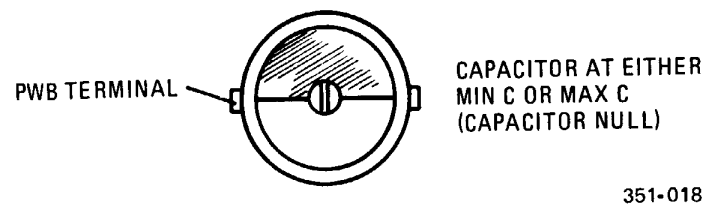
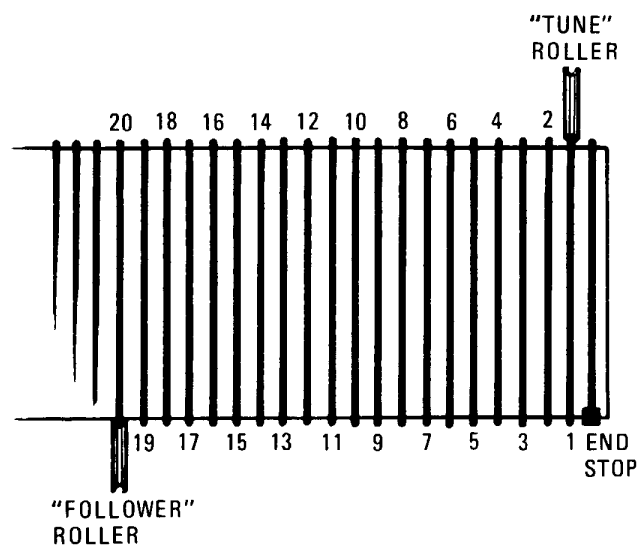

Figure 6-3. Capacitor C31



351-019

Figure 6-4. Variable Coil Roller Alignment

(d) Carefully engage the roller on the coil wire.

(3) Variable Capacitor C1 Limit Switch Adjustment

CAUTION

In the next step, do not rotate the capacitor beyond the limit switch activation point (audible click is heard), or the switch activation lever may be bent.

- (a) **Rotate the variable capacitor shaft counterwise (as viewed from the driven end of the capacitor) until the MAX C limit switch (see figure 6-1) actuates (an audible click should be heard). At this time, the blue end bell on the capacitor should be tight.**
- (b) Rotating the capacitor shaft an additional 1/4 to 1/2 turn should cause the end bell to become loose. If the end bell becomes loose at the same time as or before the limit after an additional half turn after the limit switch actuates, then do steps (c) - (e).

(c) Loosen the screw securing the capacitor limit switch assembly.

(d) Move the switch assembly slightly in the appropriate direction and retighten the screw.

NOTE

If the end bell became loose before the additional 1/4 turn, rotate the switch assembly slightly downwards. If the end bell did not become loose until after the additional 1/2 turn, move the limit switch assembly slightly upwards.

(e) Retighten the screw securing the switch assembly and repeat steps (a) and (b) above.

c. Case Assembly

Ball Gap Assembly Adjustment

The gap between the acorn nut and the brass standoff on the antenna terminal should be 0.090 to 0.100 inch (2.3 to 2.5 mm). If not, adjust the acorn nut as required to obtain this specification. See figure 6-5.

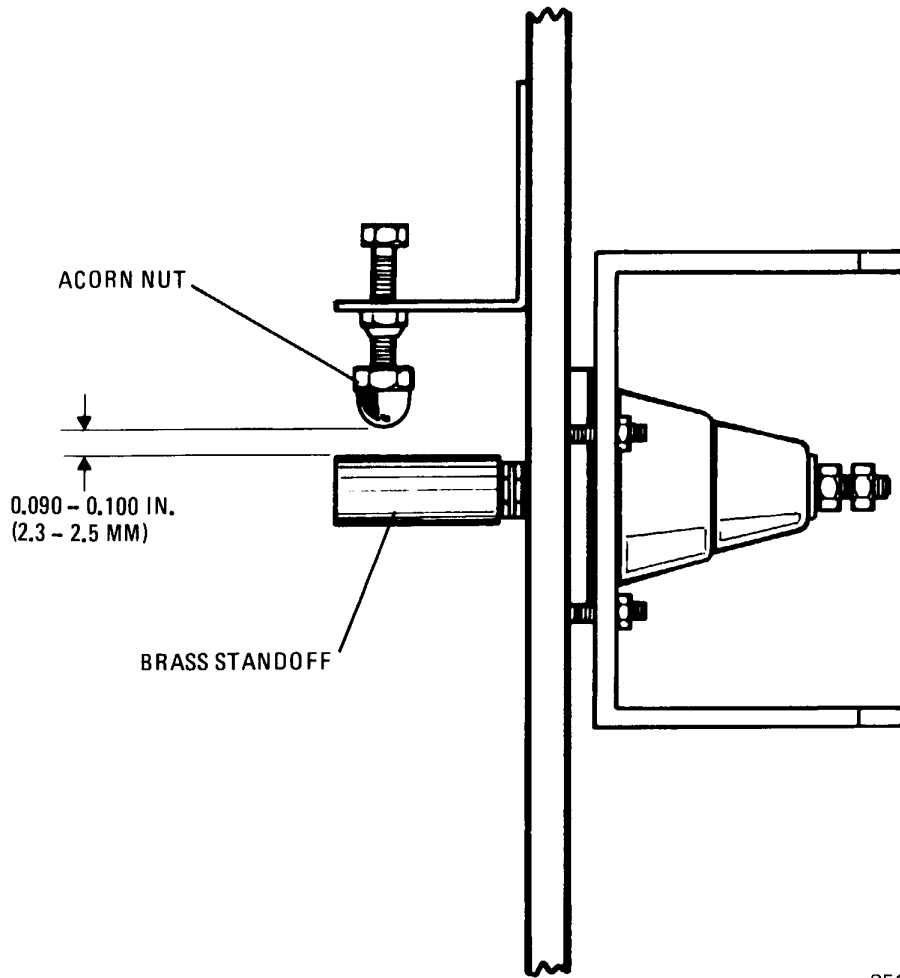

351-015

Figure 6-5. Ball Gap Assembly Adjustment

CHAPTER 7

ILLUSTRATED PARTS BREAKDOWN

Section 1. INTRODUCTION

7-1. PURPOSE. This chapter lists, illustrates, and describes the assemblies and detail parts for the 100/500 Watt Antenna Coupler. Its purpose is for the identification, requisitioning, and issuance of parts at the organizational (on-equipment) level.

7-2. SCOPE. Only parts that are coded as replaceable at the organizational level are listed in this chapter. These include the major assemblies and a few detail parts. Mounting hardware is listed only if it is used to attach a replaceable assembly or detail part and only if it is not held captive to the assembly or part. In general, the assemblies and parts installed at the time the 100/500 Watt Antenna Coupler was manufactured are listed and identified in this chapter. When an assembly or part (including vendor items), which is different from the original, was installed during the manufacture of later items, series, or blocks, all assemblies and parts are listed (and "Usable-On" coded). However, when the original assembly or part does not have continued application (no spares of the original were procured or such spares are no longer authorized for replacement), only the preferred assembly or part is listed. Also, when an assembly or part was installed during modification, and the original does not have continued application, only the preferred item is listed. Interchangeable and substitute assemblies and parts, subsequently authorized by the Government, are not listed in this chapter; such items are identified by information available through the Interchangeable and Substitute (I & S) Data Systems.

Refer to T.O. 00-25-184. When a standard size part can be replaced with an oversize or undersize part, the latter parts, showing sizes, are also listed. Repair Parts Kits and Quick Change Units are listed when they are available for replacement.

7-3. CHAPTER ORGANIZATION. This chapter is divided into two sections. Section I, INTRODUCTION, explains the purpose, scope, and organization of the chapter. Section II, MAINTENANCE PARTS LIST, consists of illustrations, in which the assemblies and detail parts of the 100/500 Watt Antenna Coupler are identified by numbers (called index numbers), followed by lists which contain parts numbers, descriptions, and other relevant data for the items identified on the illustrations.

7-4. SOURCE, MAINTENANCE, AND RECOVERABILITY (SMR) CODES. This chapter contains Air Force Peculiar In-Being Source and Repair Codes only. Definitions of these SMR codes, as well as detailed coding criteria and transposition matrices for each coding method, may be obtained from T.O. 00-25-195. Refer to page 7-3.

7-5. FEDERAL SUPPLY CODES FOR MANUFACTURERS (FSCM). The codes used in this chapter are as follows. The first list is in numerical order by FSCM; the second is in alphabetical order by manufacturer name.

T.O. 31R2-2URC-111

FSCM	NAME AND ADDRESS	NAME AND ADDRESS	FSCM
06540	Mite Corporation Amatom Electronic Hardware 446 Blake Street New Haven, Connecticut 06515	Bendix Electronic Components Division Sherman Avenue Sidney, New York 13838	77820
14304	Harris Corporation RF Communications Group 1680 University Avenue Rochester, New York 14610	Federal Screw and Bolt 3917 Kedzie Avenue Chicago, Illinois 60618	73734
21340	ITT Telecom Products Corp. Network Systems Division Highway 137 Suncrest Drive P. O. North Carroll Reece Station Johnson City, Tennessee 37601	Harris Corporation RF Communications Group 1680 University Avenue Rochester, New York 14610	14304
73734	Federal Screw and Bolt 3917 Kedzie Avenue Chicago, Illinois 60618	ITT Telecom Products Corp. Network Systems Division Highway 137 Suncrest Drive P. O. North Carroll Reece Station Johnson City, Tennessee 37601	21340
77820	Bendix Electronic Components Division Sherman Avenue Sidney, New York 13838	Kings Electronics Company Incorporated 40 Marbledale Road Tuckahoe, New York 10707	91836
81349	Military Specification Code	Mite Corporation Amatom Electronic Hardware 446 Blake Street New Haven, Connecticut 06515	06540
82877	Rotron Incorporated Custom Division 7 Hasbrouck Lane Woodstock, New York 12498	Rotron Incorporated Custom Division 7 Hasbrouck Lane Woodstock, New York 12498	82877
91836	Kings Electronics Company Incorporated 40 Marbledale Road Tuckahoe, New York 10707		
96906	Military Specification Code		

Note: Field and organizational maintenance of the modules and circuit card assemblies is limited only to the removals, replacements, and alignments given in chapter 6.

JOINT MILITARY SERVICES UNIFORM SMR CODING MATRIX T.O. 00-25-195

SOURCE		USE			MAINTENANCE REPAIR		RECOVERABILITY		ERRC CODE
1st Position	2nd Position	3rd Position	4th Position	5th Position	6th Position				
P	A Stocked	O Remove/Replace at Organizational Level	Z No Repair	Z Nonreparable Condemn at 3rd Position Level	N Nonrecoverable XB3 Condemn at Any Level				
	B Insurance								
	C Deteriorative Support								
	E Equipment, Stocked								
	F Support Equipment, Nonstocked								
	G Sustained Life Support								
K	F Intermediate Kit	F Remove/Replace at Intermediate Level	O Repair at Organizational	F Repairable Condemn at Intermediate	C Recoverable XD1 (SCARS) Condemn at Depot				
	D Depot Kit								
	B In Both Kits								
M	O Organization	D Remove/Replace at Depot Level	D Limited Repair at O or F Level	D Repairable Condemn at Depot	S Nonexpendable Support Equipment, Depot ND2				
	F Intermediate								
	D Depot								
	O Organization								
	F Intermediate								
	D Depot								
A	O Organization	D Remove/Replace at Depot Level	D Limited Repair at O or F Level	D Repairable Condemn at Depot	S Nonexpendable Support Equipment, Depot ND2				
	F Intermediate								
	D Depot								
	A Requisition NHA								
	B Reclamation from IM								
X	C Mfg Drawings	D Remove/Replace at Depot Level	L Repair at Depot	A Special Handling	U Nonexpendable Support Equipment, Organizational and Intermediate NF2				

Section II. MAINTENANCE PARTS LIST

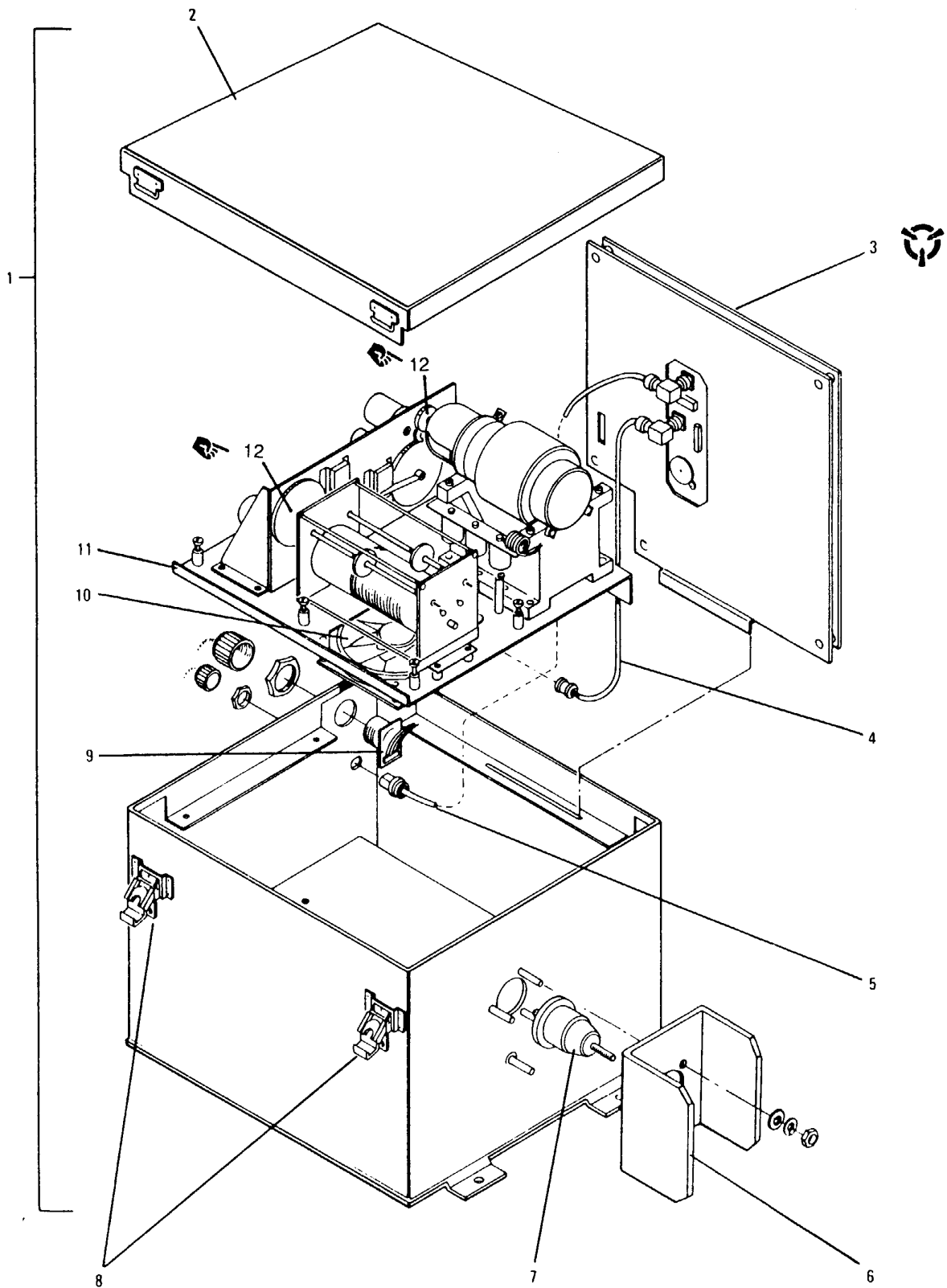

351-020

Figure 7-1. 100/500 Watt Antenna Coupler, CU-2310/URC

ILLUSTRATED PARTS BREAKDOWN

Fig. & Index No.	Part No.	FSCM	Description							Units Per Assy	Usable on Code	SMR Code
			1	2	3	4	5	6	7			
7-1-	10094-0000	14304	Coupler, Antenna*									PEODD
1	10094-0100	14304	. Coupler, Antenna							1		PAODD
2	10094-0510	14304	. Cover, Access							1		XB
	H-6612	96906	. Strike, Catch							4		XB
	MS24243/1-F403	96906	. Rivet, Blind (AP)							8		XB
	10094-0521	14304	. Gasket							4		MDD
3	10094-3000	14304	. Logic PWB Assy, A1							1		PAODD
4	10094-0550	14304	. Cable Assy, RF							1		MDO
	KC-59-105	91836	. Connector, Receptacle, Elec.							2		PAOZZ
	M39012/16-0014	81349	. Connector, Receptacle, Elec.							1		PAOZZ
5	10094-0540	14304	. Cable Assy, RF							1		MDO
	755017A4016-2	14304	. Connector, Receptacle, Elec.							1		PAOZZ
	KC-59-105	91836	. Connector, Receptacle, Elec.							Ref		PAOZZ
	M39012/25-0012	81349	. Cap, Prot, Dumr, Seal							1		PAOZZ
6	10094-0505	14304	. Bracket							1		XB
	MS35649-284	96906	. Nut							3		PAOZZ
	MS35338-137	96906	. Washer, Lock							3		PAOZZ
	MS15795-807	96906	. Washer, Flat							3		PAOZZ
7	1960-4000	14304	. Insulator Assy							1		
	423-0015	14304	. Gasket Cork (AP)							1		MDD
	8697-B	06540	. Spacer							1		XB
	8045NP	73734	. Nut, Hex							3		PAOZZ
	1390	73734	. Washer, Lock							2		PAOZZ
	3242513	21340	. Washer, Flat							2		PAOZZ
8	H-6611	96906	. Catch, Clamping							4		XB
	MS24243/1-F402	96906	. Rivet, Blind							12		XB
9	10094-0140	14304	. Connector Assy							1		PAOZZ
	10-37087-20	77820	. Cap, Prot, Dumr, Seal							1		XA
10	028868	82877	. Fan, Tube, Axial							1		PAOZZ
	MS51957-31	96906	. Screw, Machine (AP)							4		PAOZZ
	MS35338-136	96906	. Washer, Lock (AP)							4		PAOZZ
11	10094-0120	14304	. Lower Shelf Assy, A2							1		PAODD
12	DT16-3	29964	. Coupler, Shaft, Flex							2		PAOZZ
	Z06-0011-006	14304	. Coupler, Flex							1		PAFZZ

* Includes Ancillary Kit (See Figure 7-2).

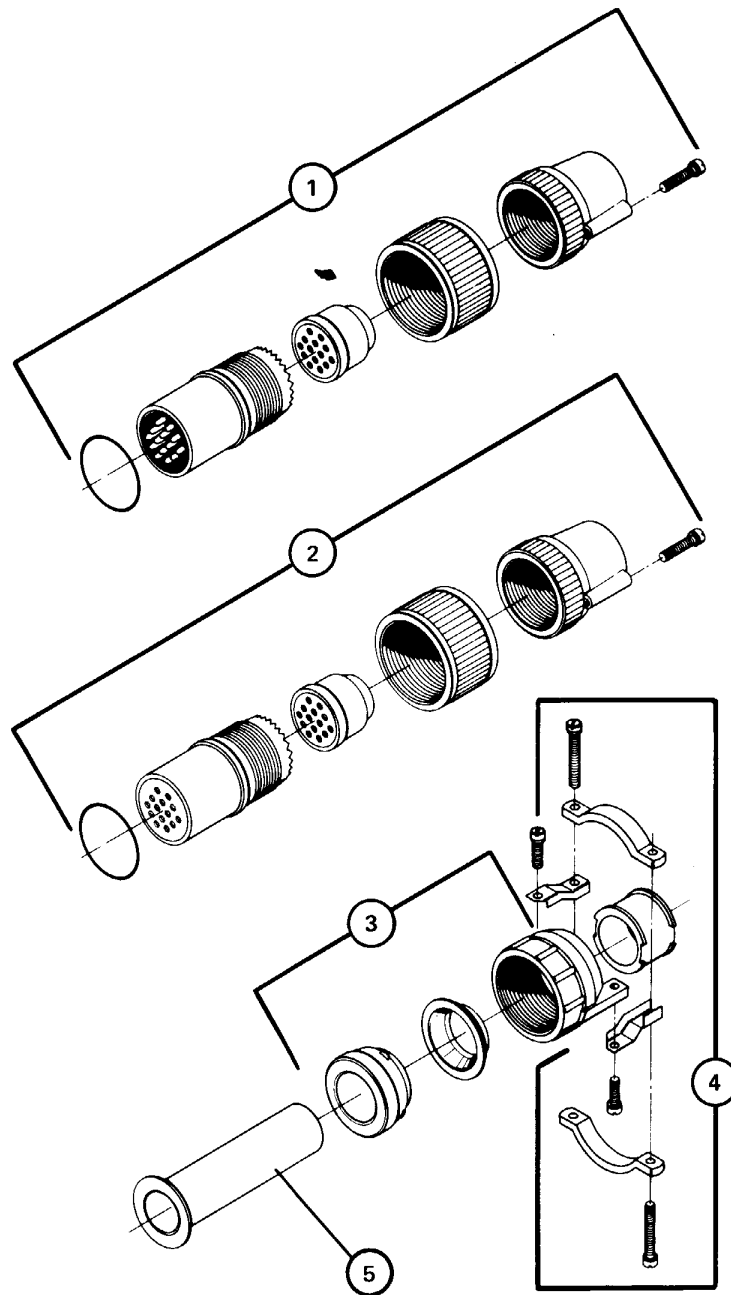

351-021

Figure 7-2. Ancillary Kit for 100/500 Watt Antenna Coupler

ILLUSTRATED PARTS BREAKDOWN

Fig. & Index No.	Part No.	FSCM	Description 1 2 3 4 5 6 7	Units Per Assy	Usable on Code	SMR Code
7-2-	10094-0060	14304	Ancillary Kit			XB
1	MS3106A20-27P	81349	. Connector, Plug, Elec	1		PAOZZ
2	MS3106A20-27S	96906	. Connector, Recept, Elec	1		PAOZZ
3	M85049/1-12B	81349	. Clamp, Cable	2		PAOZZ
4	10-36233-243	77280	. Clamp, Cable	2		PAOZZ
5	MS3420-12B	96906	. Bushing, Elect	1		XB

REFERENCE DESIGNATOR INDEX

Reference Designator	Figure & Index No.	Part Number	Reference Designator	Figure & Index No.	Part Number
A1	7-1-3	10094-3000	W1P1	7-1-5	755017A4016-2
A2	7-1-11	10094-0120	W1P2	7-1-5	KC-59-105
A3J1/A3W1P1	7-1-9	10094-0140	W2	7-1-4	10094-0550
B1	7-1-10	028868	W2P1	7-1-4	KC-59-105
W1	7-1-5	10094-0540	W2P2	7-1-4	M39012/16-0014

CHAPTER 8
FOLDOUT DRAWINGS

LIST OF 100/500 WATT ANTENNA COUPLER FOLDOUT DRAWINGS.

- FO-1 Family Tree 100/500 Watt Antenna Coupler
- FO-2 100/500W Coupler Functional Block Diagram
- FO-3 Component Location Diagram
- FO-4 Antenna Coupler Interconnection Diagram

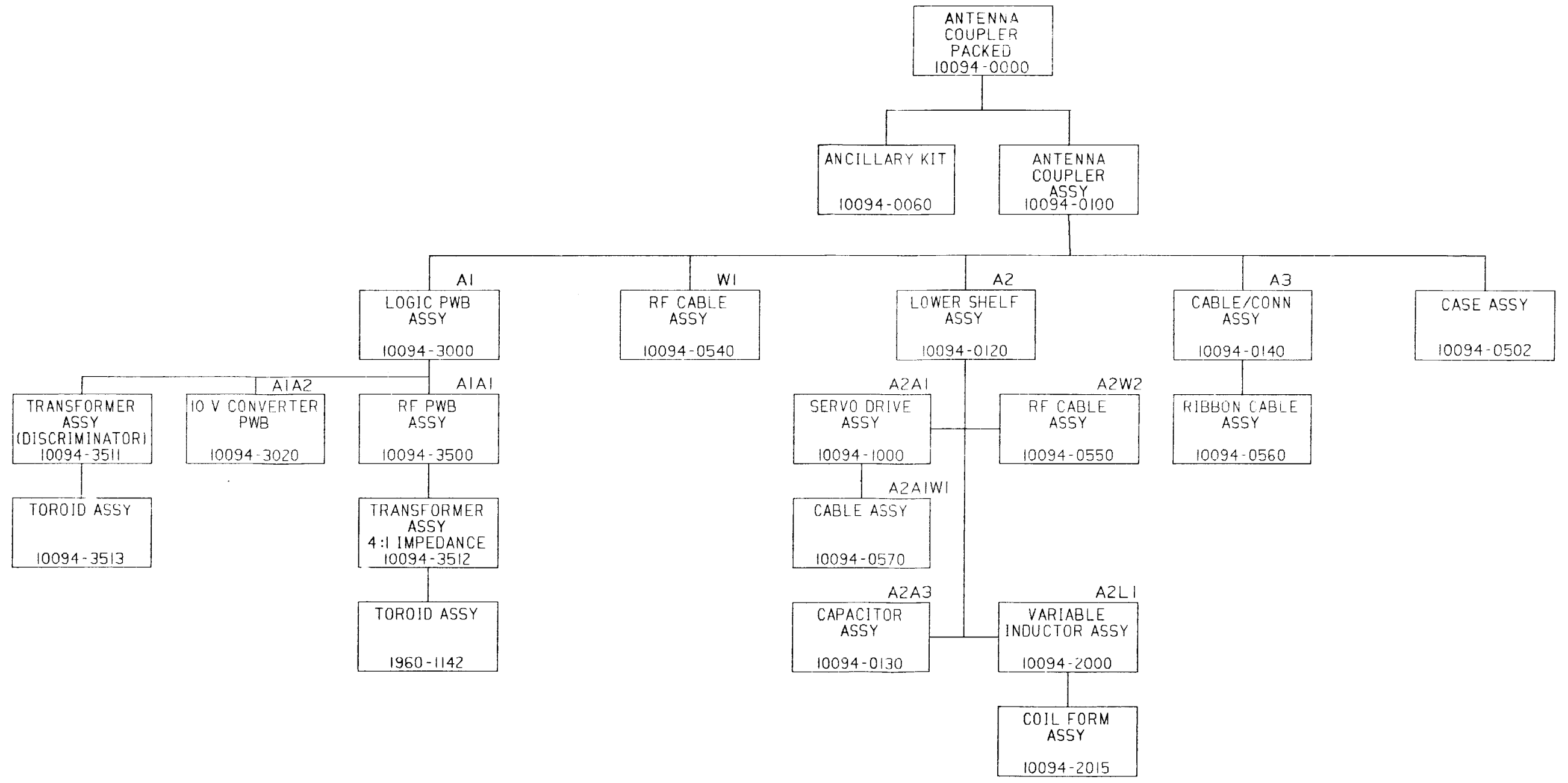

Figure FO-1. Family Tree 100/500 Watt Antenna Coupler

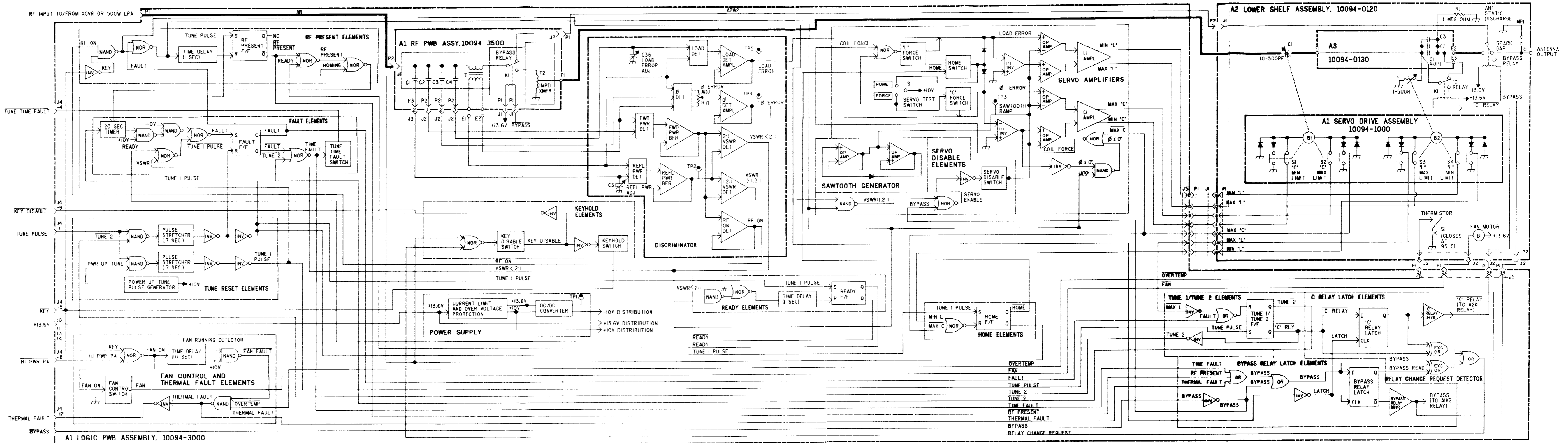

Figure FO-2. 100/500W Coupler Functional Block Diagram

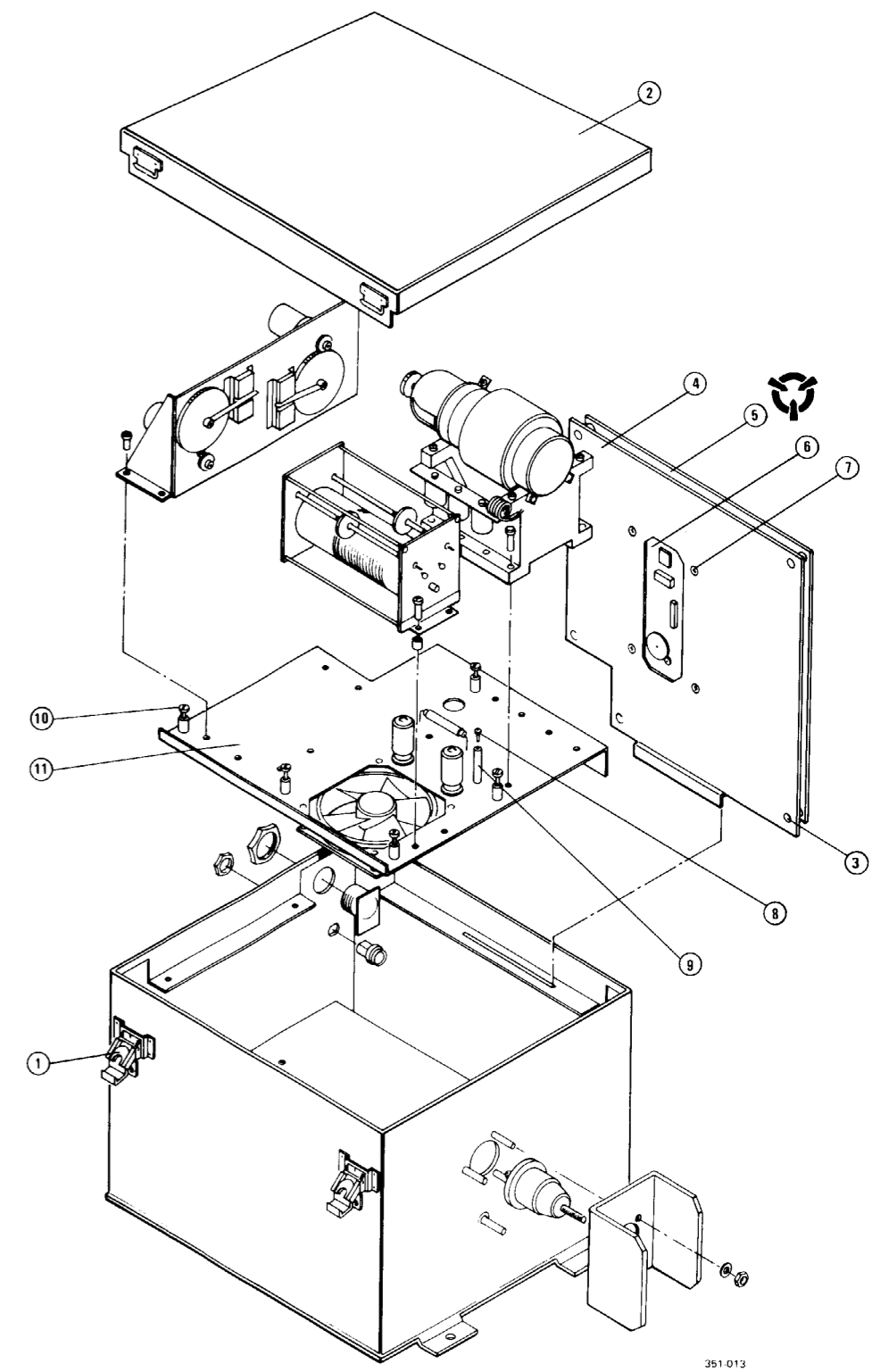

Figure FO-3. Component Location Diagram

NOTE UNLESS OTHERWISE SPECIFIED:

1. PARTIAL REFERENCE DESIGNATIONS ARE SHOWN FOR DETAIL PARTS. PREFIX THESE WITH UNIT NO. AND/OR ASSEMBLY DESIGNATIONS SHOWN ON DRAWING TO OBTAIN COMPLETE DESIGNATIONS.
2. ALL RESISTOR VALUES ARE IN OHMS, 1/4W, ±5%.
3. ALL CAPACITOR VALUES ARE IN MICROFARADS (µF).
4. ALL INDUCTANCE VALUES ARE IN MICROHENRIES (µH).
5. VENDOR PART NO. CALLOUTS ARE FOR REFERENCE ONLY. COMPONENTS ARE SUPPLIED PER PART NO. IN PARTS LIST.
6. DC RESISTANCES OF INDUCTIVE ELEMENTS (CHOKES, COILS, MOTOR WINDINGS, ETC.) ARE LESS THAN 1 OHM.
7. PANEL DECALS ARE INDICATED BY BOLD TYPE IN A BOLD BOX, E.G., **ON/OFF**.
8. ALL RELAYS ARE SHOWN IN THE DE-ENERGIZED STATE.

HIGHEST REFERENCE DESIGNATION	
REFERENCE DESIGNATIONS NOT USED	

1 CLOSES @ 95°C

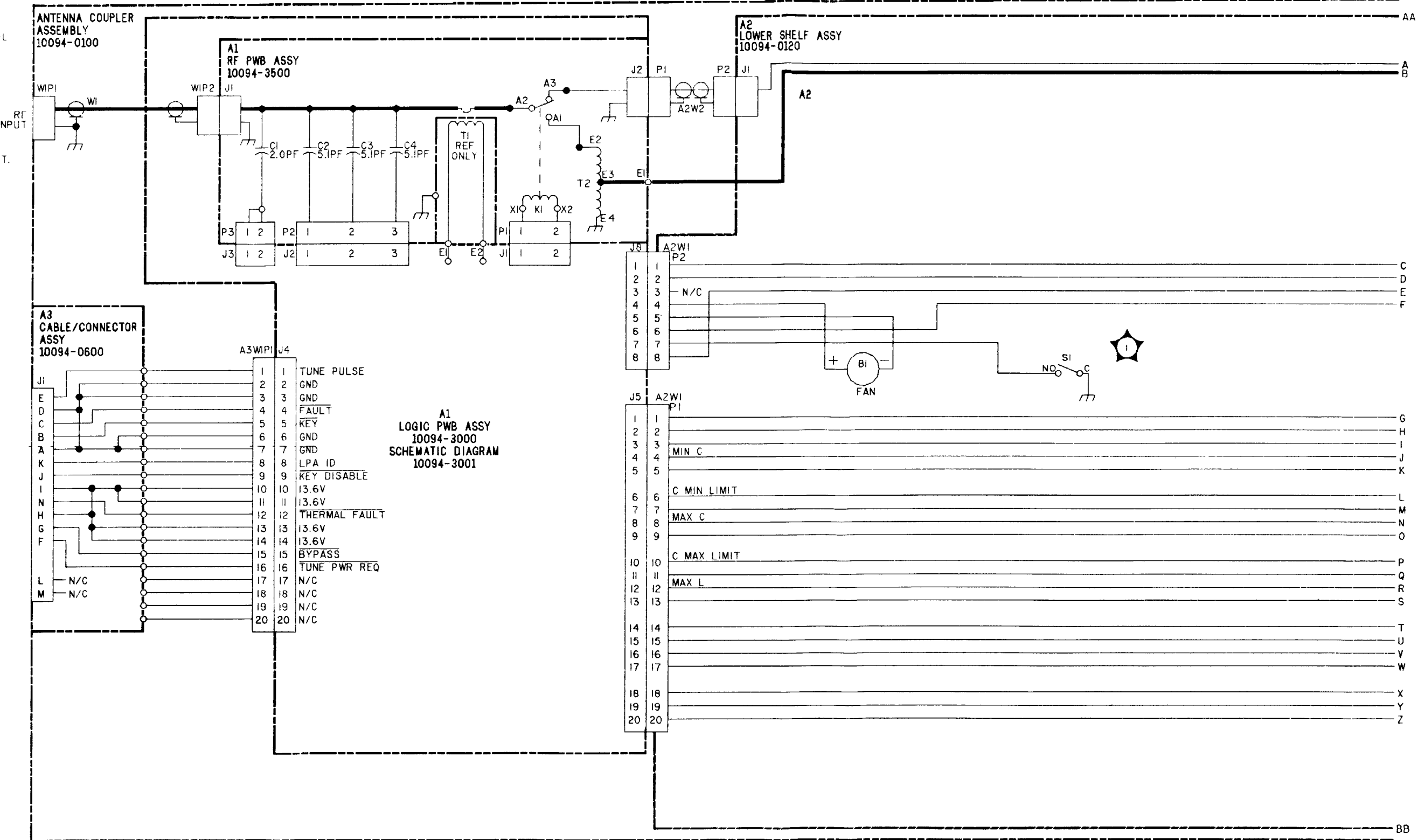

Figure FO-4. Antenna Coupler Interconnection Diagram (Sheet 1 of 2)

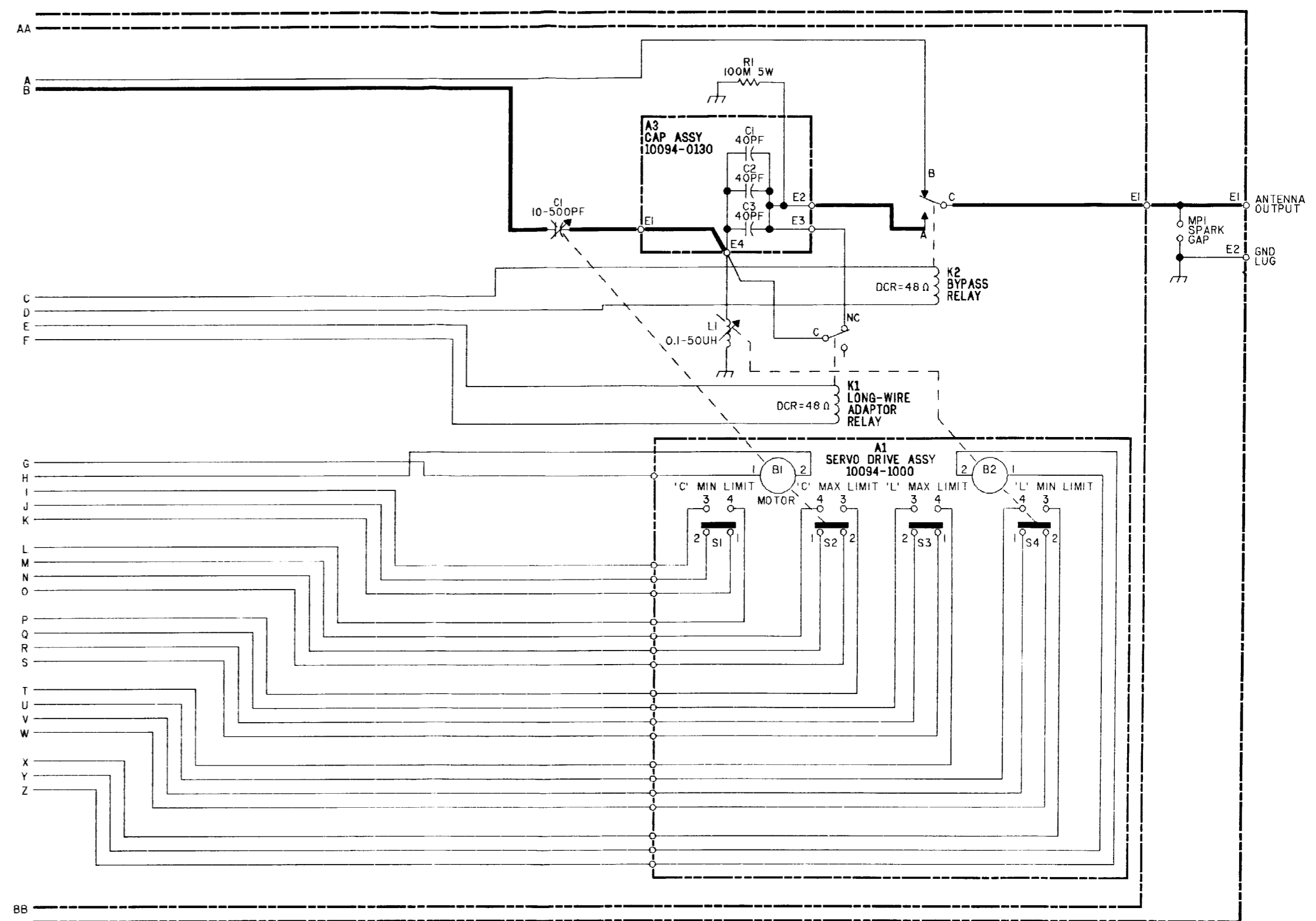

Figure FO-4. Antenna Coupler Interconnection Diagram (Sheet 2 of 2)